



INDUSTRIAL PROCESS AND
COMMERCIAL VENTILATION SYSTEMS

WALL MOUNTED FANS

WPD | WPB



WALL MOUNTED FANS



Model WPD
with "E" Series Impeller

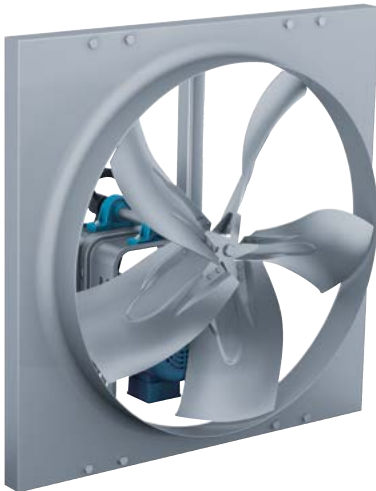

Model WPB
with "L1" Series Impeller

Overview

WPB | WPD

Twin City Fan & Blower Model WPD Medium-Duty and Model WPB Light- and Medium-Duty Wall Mounted Fans are specifically designed for cost effective, general-purpose ventilation. All models are available in either exhaust or supply configurations. The steel panel design is available with cast aluminum or fabricated steel impellers to meet specific application requirements. Regardless of the application, the WPD and WPB Series offers a high quality, cost competitive impeller fan solution.

Typical Applications Include

Warehouse Ventilation, Restroom Exhaust, Elevator Shaft, Stairwell Exhaust, Attic Exhaust, Data Center Ventilation, Gymnasium Ventilation, Filtered Supply, Garage Exhaust, General HVAC, Farm Exhaust, Foundry Ventilation, Factory Ventilation, Greenhouse Ventilation

Configurations

Available in Both Direct and Belt Driven Configurations

Impeller Types

"L1" and "L2" Fabricated Steel Impellers; "B" and "E" Die Cast Aluminum Impellers; "C" Cast Aluminum Impellers; "Z" Fabricated Steel Impellers

Certifications

AMCA Sound/Air and FEI, UL 705 Listed for Electrical



Models WPD and WPB are UL/cUL 705 listed for electrical, File No. E158680.



Twin City Fan & Blower certifies that the Model WPD and WPB Wall Mounted Fans shown herein are licensed to bear the AMCA Seal. Certified performance data may be found in Twin City Fan & Blower's Fan Selector software.



Scan the QR code to search Twin City Fan & Blower's AMCA-certified products.



For complete product performance, drawings and available accessories, download our Fan Selector software at tcf.com.

Overview

WPB | WPD

Construction Features

- Cast aluminum or fabricated steel impellers.
- Steel panel with deep formed inlet venturi, which distributes air velocity uniformly.
- Pre-punched mounting holes for ease of installation.
- Motor supports are constructed of heavy-gauge galvanized steel.
- Fans designed for exhaust and supply service are provided with motor and drive located on the interior side of the building.
- Pre-engineered accessories to accommodate any installation.
- Dynamically balanced impellers for quiet, vibration-free operation.
- Designed for continuous-duty.
- Cast iron pillow block bearings selected for L50 average life of 200,000 hours at maximum cataloged operating speeds.

WPB

21" to 60" impeller diameters
Airflow to 62,800 CFM
Static pressure to 1" w.g.



WPD

14" to 48" impeller diameters
Airflow to 35,300 CFM
Static pressure to 1" w.g.



Energy Regulations

Twin City Fan & Blower supports energy efficiency regulations enacted by the Department of Energy (DOE) and energy commissions of specific states. The selection and application of fan products is a significant part of these regulations. Engineers and specifiers must understand how to apply TCF products to their specific applications to meet efficiency requirements. Twin City Fan & Blower has made significant investments in product testing to assure users will receive the most efficient products available. Developments in the Fan Selector software are in place to help aid in product selection to meet the efficiency requirements as stipulated in the regulations. Visit tcf.com for the latest on fan energy efficiency regulations.

Impellers

WPB | WPD

FAN SIZE	DIRECT DRIVE	BELT DRIVEN
14	B, E	—
16	B, E	—
18	B, E	—
21	B, E	L1, L2, B, E
24	B, E, Z	L1, L2, B, E, Z
30	B, E, Z	L1, L2, B, E, Z
36	B, E, Z	L1, L2, B, E, Z
42	B, E, Z	L1, L2, B, E, Z
48	B, E	L1, L2, B, E
54	—	L1, L2, B, C
60	—	L1, L2, C

Impeller Availability

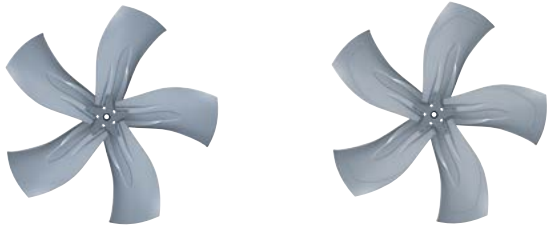

"L1 & L2" Fabricated Steel Impellers

The "L1" and "L2" series features fixed pitch, fabricated steel, 5-bladed impellers. Galvanized steel impeller blades are riveted to galvanized steel hubs. Available in 8 sizes from 21" to 60" diameters in either standard L1 construction or reinforced L2 construction.

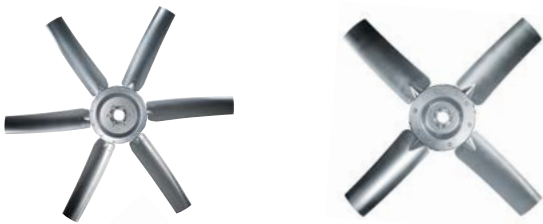

"B" Die Cast Aluminum Impellers

The "B" series features a die cast aluminum impeller available in 4, 5 and 6 blade designs. Blade angles are factory set and mounted in a die cast aluminum hub. "B" impellers are available in 14" through 54" diameters.

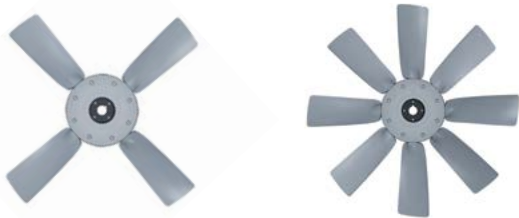

"E" Die Cast Aluminum Impellers

The "E" series features a die cast aluminum impeller available in 4 and 8 blade designs. Blade angles are factory set and mounted in a die cast aluminum hub. "E" impellers are available in 14" through 48" diameters.

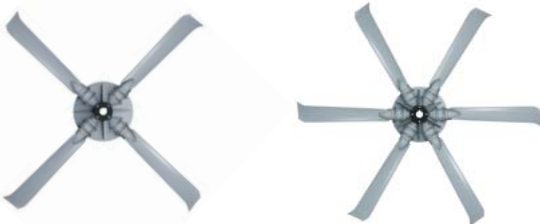

"C" Cast Aluminum Impellers

The "C" series is a cast aluminum impeller available in 4 and 6 blade designs, and is available in 54" and 60" diameters only. Blade angles are factory set and mounted in a cast aluminum hub.



"Z" Fabricated Steel Impellers

The "Z" series features a fixed pitch, fabricated steel, 5-bladed impeller. Steel blades are continuously-welded to a heavy gauge hub at the customer's selected blade angle. "Z" impellers are available in 24" through 42" diameters.

Pressure Drops

Supply & Exhaust

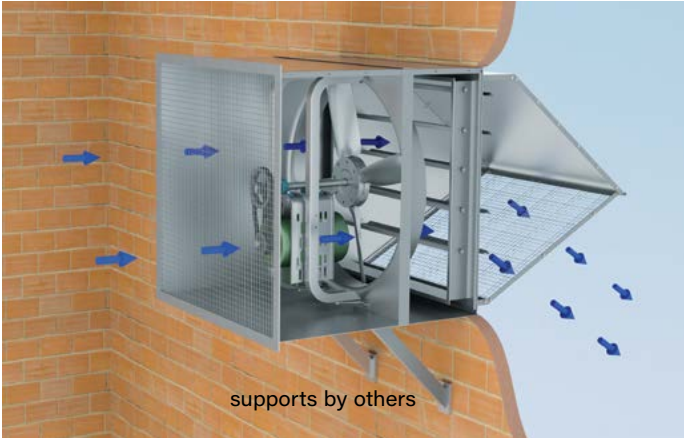

EXHAUST FAN

in Wall Box with Backdraft Damper & Weather Hood

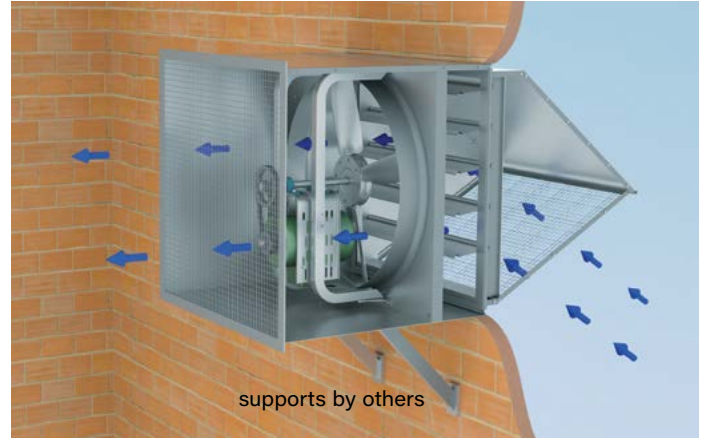

SUPPLY FAN

in Wall Box with Backdraft Damper & Weather Hood

FAN SIZE	CFM	PRESS. DROP (IN. W.G.)	
		EXHAUST	SUPPLY
14	1000	0.04	0.06
	1200	0.06	0.09
	1400	0.09	0.12
	1600	0.11	0.16
	1800	0.14	0.20
	2000	0.18	0.25
	2200	0.22	0.30
2400	0.26	0.36	
16	1600	0.07	0.10
	1800	0.09	0.12
	2000	0.11	0.15
	2200	0.13	0.18
	2400	0.15	0.21
	2600	0.18	0.25
	2800	0.21	0.29
3000	0.24	0.34	
3500	0.32	0.46	
18	2000	0.07	0.09
	2200	0.08	0.11
	2400	0.10	0.13
	2600	0.11	0.16
	2800	0.13	0.18
	3000	0.15	0.21
	3500	0.20	0.29
4000	0.27	0.37	
4500	0.34	0.47	
5000	0.41	0.58	
21	2400	0.05	0.07
	2600	0.06	0.09
	2800	0.07	0.10
	3000	0.08	0.11
	3500	0.11	0.16
	4000	0.15	0.20
	4500	0.18	0.26
5000	0.23	0.32	
5500	0.27	0.39	
6000	0.33	0.46	
6500	0.38	0.54	
24	3500	0.07	0.09
	4000	0.09	0.12
	4500	0.11	0.15
	5000	0.13	0.19
	6000	0.19	0.27
	7000	0.26	0.37
	8000	0.34	0.48
9000	0.43	0.61	
10000	0.53	0.75	

FAN SIZE	CFM	PRESS. DROP (IN. W.G.)	
		EXHAUST	SUPPLY
30	5000	0.05	0.08
	6000	0.08	0.11
	7000	0.11	0.15
	8000	0.14	0.20
	9000	0.18	0.25
	10000	0.22	0.31
	11000	0.26	0.37
	12000	0.31	0.44
	13000	0.37	0.52
	14000	0.43	0.60
15000	0.49	0.69	
36	7000	0.05	0.07
	8000	0.07	0.09
	9000	0.09	0.12
	10000	0.11	0.15
	11000	0.13	0.18
	12000	0.15	0.21
	13000	0.18	0.25
	14000	0.21	0.29
	16000	0.27	0.38
	18000	0.34	0.48
20000	0.42	0.59	
22000	0.51	0.72	
42	10000	0.06	0.08
	11000	0.07	0.10
	12000	0.08	0.12
	13000	0.10	0.14
	14000	0.11	0.16
	16000	0.15	0.21
	18000	0.19	0.26
	20000	0.23	0.32
	22000	0.28	0.39
	24000	0.33	0.46
26000	0.39	0.55	
28000	0.45	0.63	
48	14000	0.07	0.09
	16000	0.09	0.12
	18000	0.11	0.15
	20000	0.13	0.19
	22000	0.16	0.23
	24000	0.19	0.27
	26000	0.23	0.32
	28000	0.26	0.37
	30000	0.30	0.43
	32000	0.35	0.49
34000	0.39	0.55	
36000	0.44	0.62	

FAN SIZE	CFM	PRESS. DROP (IN. W.G.)	
		EXHAUST	SUPPLY
54	11000	0.03	0.04
	12000	0.03	0.04
	13000	0.04	0.05
	14000	0.04	0.06
	15000	0.05	0.07
	16000	0.05	0.08
	18000	0.07	0.10
	20000	0.08	0.12
	22000	0.10	0.14
	24000	0.12	0.17
	26000	0.14	0.20
	28000	0.17	0.23
30000	0.19	0.27	
32000	0.22	0.30	
34000	0.24	0.34	
36000	0.27	0.39	
38000	0.30	0.43	
40000	0.34	0.48	
42000	0.37	0.52	
44000	0.41	0.58	
60	12000	0.02	0.03
	13000	0.02	0.03
	14000	0.03	0.04
	15000	0.03	0.04
	16000	0.04	0.05
	18000	0.04	0.06
	20000	0.06	0.08
	22000	0.07	0.09
	24000	0.08	0.11
	26000	0.09	0.13
	28000	0.11	0.15
	30000	0.12	0.17
32000	0.14	0.20	
34000	0.16	0.22	
36000	0.18	0.25	
38000	0.20	0.28	
40000	0.22	0.31	
42000	0.24	0.34	
44000	0.27	0.38	
46000	0.29	0.41	
50000	0.34	0.49	
52000	0.37	0.52	
54000	0.40	0.57	
56000	0.43	0.61	
58000	0.46	0.65	

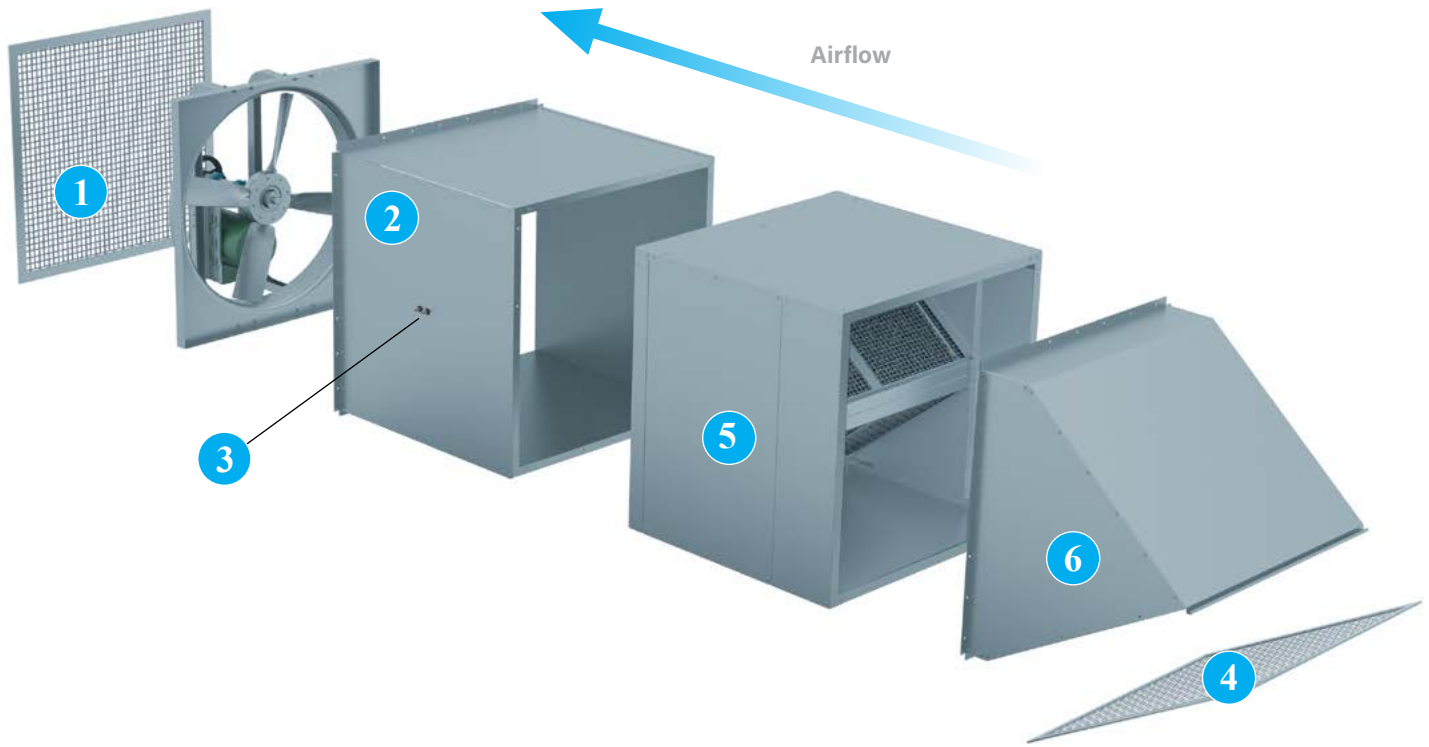

1 Removable Screen Standard component of wall box and motor side guard. Screen is available with bolted removable or hinged construction. Allows for access to motor, bearings and drive components.

2 Wall Box is used to mount the fan and accessories cleanly into a wall, and provides the strongest and safest way to mount wall fans. Wall boxes are constructed of 16-gauge galvanized steel and are provided with heavy-gauge mounting flanges with prepunched mounting holes for ease of installation. Available fully assembled or as a kit (field assembly required) to reduce shipping costs. Wall supports are provided by others.

3 Extended Lube Lines with grease fittings are extended to the outside of the fan housing.

4 Bird Screen protects the fan's internal components from entry of birds.

5 Filter Box For applications requiring filtered air, filter boxes are available with wall box or wall collar and fan in supply configuration. Filter box contains 2" thick aluminum washable filters and access panels as standard. Disposable filters and 1" options are also available upon request. Contact factory for more information.

6 Weather Hood keeps snow and rain from entering the building and to prevent wind from altering the performance of the fan and backdraft damper. The weather hood is designed to fit over the backdraft damper and can be installed to a wall collar via the mounting flanges and prepunched mounting holes. Weather hoods are constructed of G90 galvanized steel and are standard with a removable galvanized steel, wire mesh, bird screen. Available fully assembled or as a kit (field assembly required). Weather hoods are not weather tight when used with supply fans.

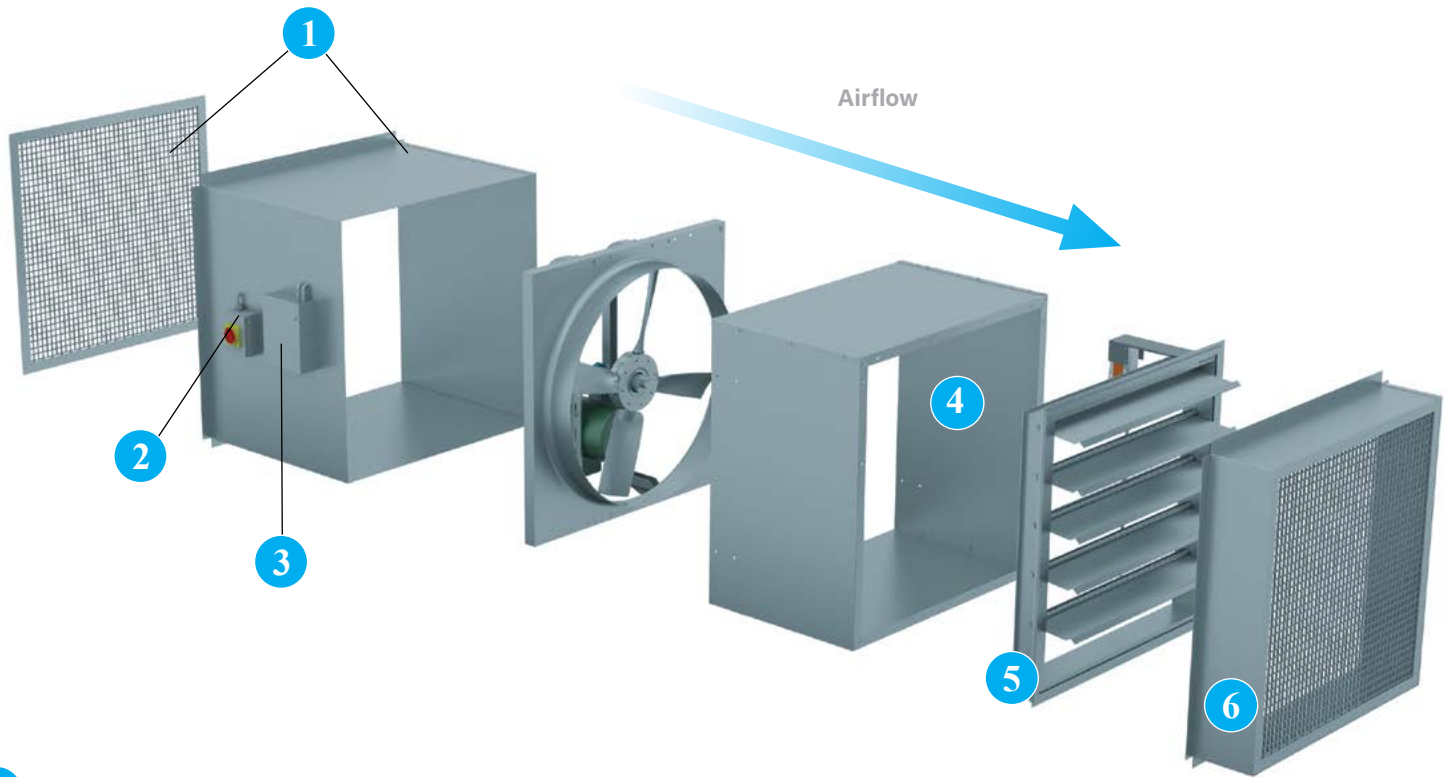

- 1 OSHA Motor Side Guard with Removable Screen** meets OSHA standards by completely enclosing the motor and drive components. Motor side guards are constructed of galvanized steel side sheets and a removable wire mesh screen. Prepunched mounting holes allow for easy installation to the fan. Can be used with or without a wall collar.
- 2 NEMA 4 Disconnect Switch** provides positive electrical shutoff when fan cleaning or maintenance of fan and is water and dust tight. Switch is available shipped loose for field mounting and wiring or factory mounted and wired. See page 8 for other available disconnect switches.
- 3 Single Point Wiring** Available with factory assembled motor side guard or wall box, wired disconnect switch and motorized backdraft damper. Single point wiring option provides a single location for making connections to the damper actuator and disconnect switch.
- 4 Wall Collars** are an economical alternative to the wall box. Wall collars are constructed of 16-gauge galvanized steel. Heavy-gauge mounting flanges with prepunched mounting holes are provided for ease of installation. Available fully assembled or as a kit (field assembly required). If motor side of fan is to be enclosed, add OSHA motor side guard. Wall supports by others.
- 5 Backdraft Dampers** are used to keep the elements and unwanted air out of the building when the fan is not in use. They are constructed to easily fasten to the wall box or wall collar so that the weather hood or damper guard can easily fit over it. The standard damper frame is constructed of .062 extruded aluminum and the blades are constructed of 26-gauge mill finished aluminum. The leading edge of each damper blade is flanged with a vinyl seal for effective weather protection and quiet closing. Heavy duty/high velocity dampers are provided when the fan is selected at higher air volumes (see velocity table on page 11). Frame and blades are .080 extruded aluminum. The blades freely pivot open or close on stainless steel pivot pins on both types. Motorized options are available. See page 11 for additional information on backdraft damper limits.
- 6 Damper Guard** protects the backdraft damper when a weather hood is not used. It is constructed of 18-gauge G90 galvanized steel side sheets and a galvanized steel screen. The screening complies with OSHA standards and will keep birds out of the fan and building. Mounting flanges and prepunched mounting holes are provided for ease of installation.



NEMA 1 Disconnect Switch

Disconnect switches provide positive electrical shutoff during fan cleaning or maintenance.

NEMA 1 Disconnect Switch (Standard)

A NEMA 1 disconnect switch is available shipped loose for field mounting and wiring or factory mounted and wired with ODP or TEFC motors.



NEMA 3R Disconnect Switch

NEMA 3R Disconnect Switch

A NEMA 3R, rain proof, disconnect is available shipped loose for field mounting and wiring or factory mounted and wired externally.

NEMA 4 Disconnect Switch

A NEMA 4, water and dust tight, disconnect is available shipped loose for field mounting and wiring or factory mounted and wired externally.



NEMA 4 Disconnect Switch

NEMA 7/9 Disconnect Switch

A NEMA 7/9 disconnect switch is recommended on fans with explosion proof motors. The NEMA 7/9 switch is designed for use with fans operating in hazardous environments. Available shipped loose for field mounting and wiring. (Not shown.)



WPB - E - 24 - B - 1 - 05 - 25

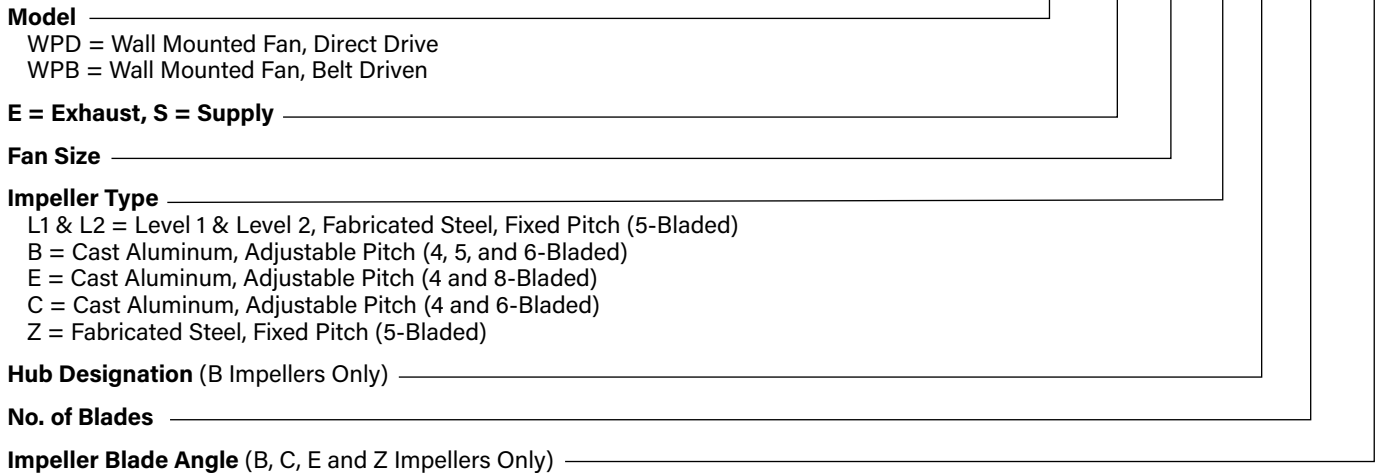

Model Comparison

Twin City Fan & Blower offers a full line of wall mounted fans available in both direct drive and belt driven. Each model and impeller type has been designed for a wide variety of commercial market applications. No matter what the requirements are, Twin City Fan & Blower has the wall mounted fan to suit the application.

Direct Drive

LEVEL	IMPELLER CONSTRUCTION	MODEL	SIZE RANGE	PERFORMANCE RANGE CFM	STATIC PRESSURE CAPABILITY
1	Fabricated Aluminum Blades Riveted to Steel Hubs	TCPE	8-24	131 to 7,320	Up to 0.625 in. w.g.
3	Cast Aluminum Blades and Hubs	WPD	14-48	883 to 35,350	Up to 1.00 in. w.g.
	Steel Blades and Hubs		24-42	3,100 to 30,000	
4	Cast Aluminum Blades and Hubs	TCWP	12-48	686 to 39,980	Up to 1.50 in. w.g.
		TCWPX	24-60	1,640 to 72,000	

Belt Driven

LEVEL	IMPELLER CONSTRUCTION	MODEL	SIZE RANGE	PERFORMANCE RANGE CFM	STATIC PRESSURE CAPABILITY
1	Galvanized Steel Blades Riveted to Galvanized Hubs	WPB L1	21-60	2,970 to 35,100	Up to 0.375 in. w.g.
2	Reinforced Galvanized Steel Blades Riveted to Galvanized Hubs	WPB L2	21-60	3,450 to 47,600	Up to 0.75 in. w.g.
3	Cast Aluminum Blades and Hubs	WPB L3	21-60	2,200 to 56,700	Up to 1.00 in. w.g.
	Steel Blades and Hubs		24-42	3,300 to 33,400	
4	Cast Aluminum Blades and Hubs	TCWP	24-48	3,600 to 38,000	Up to 1.50 in. w.g.
		TCWPX	24-72	4,000 to 75,000	

MOUNTING ARRANGEMENTS

Flush with Outside Wall

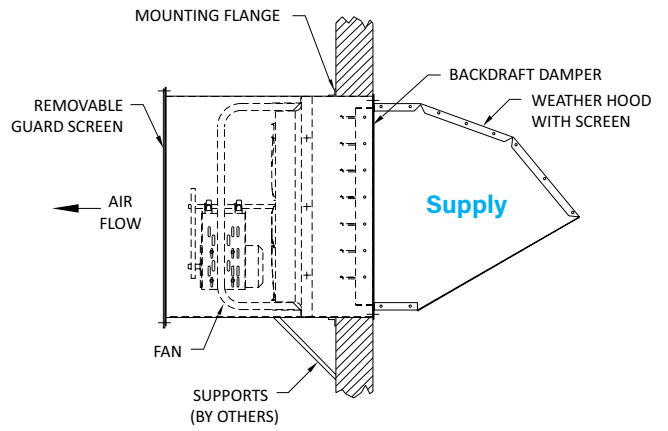
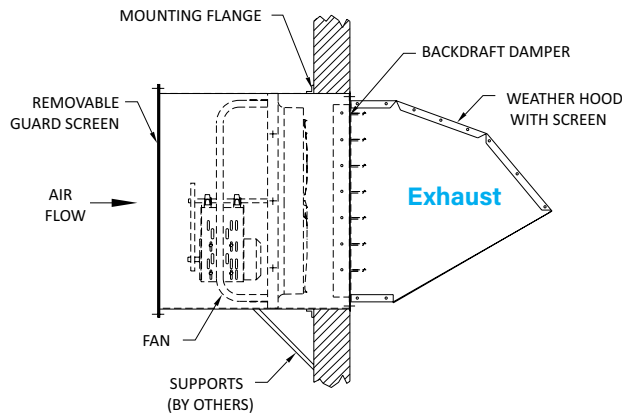

Middle of Wall

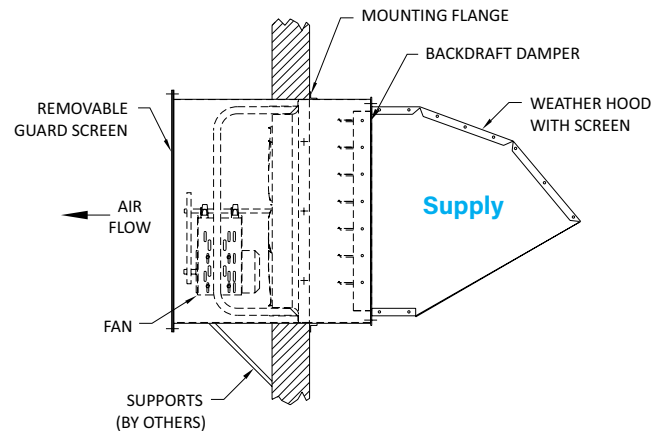
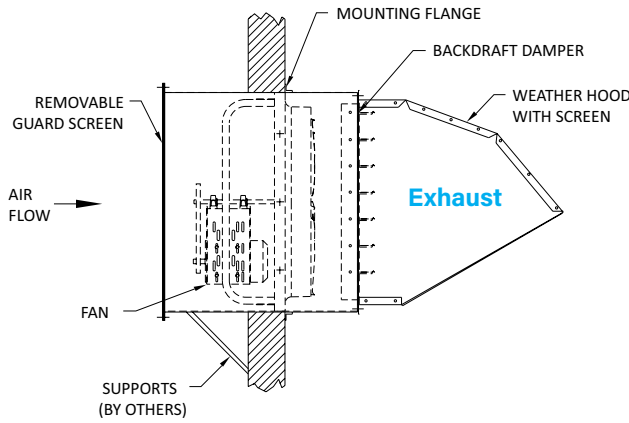

Flush with Interior Wall

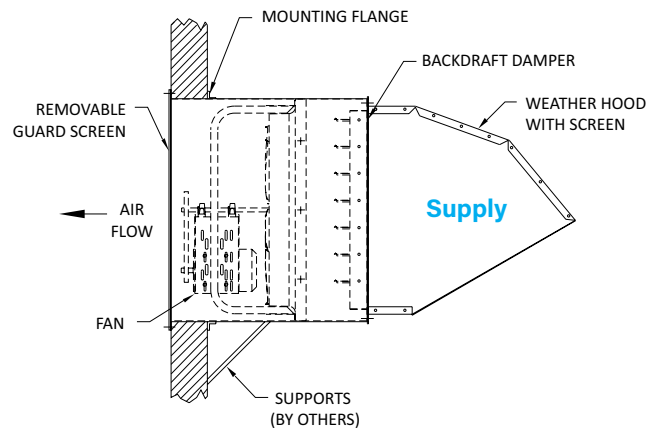
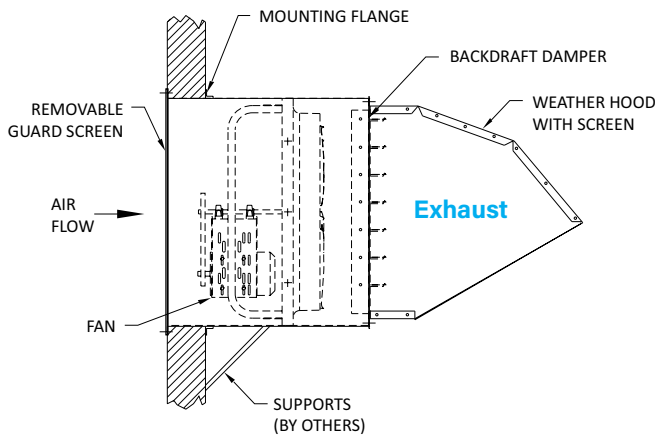

Mounting without Accessories

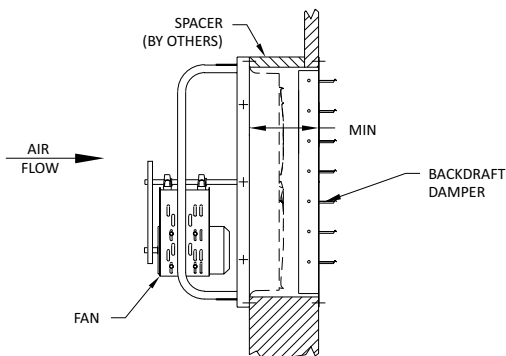

SIZE	MIN.
14	16
16	16
18	16
21	16
24	16
30	16
36	16
42	16
48	16
54	19
60	19

Dimensions are in inches.

TO ACHIEVE THE MINIMUM DIMENSION, THIS INSTALLATION REQUIRES A SPACER (BY OTHERS) BETWEEN THE FAN AND THE WALL.

IF THE WALL IS EQUAL TO OR GREATER THAN THE MINIMUM DIMENSION, THE FAN CAN BE MOUNTED DIRECTLY TO THE WALL.

Approx. Shipping Weight (LB.)

FAN SIZE	WPD				WPB							
	B	E4	E8	Z5	L1	L2	B	E4	E8	C3	C6	Z5
14	41	41	45	—	—	—	—	—	—	—	—	—
16	47	47	49	—	—	—	—	—	—	—	—	—
18	50	50	52	—	—	—	—	—	—	—	—	—
21	58	58	69	—	61	69	72	72	75	—	—	—
24	74	74	77	78	69	74	80	80	86	—	—	90
30	99	99	105	111	90	100	103	103	118	—	—	124
36	127	127	154	175	115	127	139	139	146	—	—	161
42	195	195	210	229	147	167	197	197	212	—	—	267
48	208	208	224	—	160	248	273	273	289	—	—	—
54	—	—	—	—	184	276	345	—	—	345	369	—
60	—	—	—	—	261	368	—	—	—	423	438	—

Material Specification

FAN SIZE	GAUGE OF MATERIAL												SHAFT SIZE (IN.)				
	FAN PANEL			DRIVE FRAME			IMPELLERS				HUBS		WPB				
	WPD	WPB		WPD	WPB		L1/L2	B	E	C	Z	L1/L2	Z	L1	L2	B/E/C/Z	
		L1/L2	B/E/C/Z		L1/L2	B/E/C/Z											
14	18	—	—	14	—	—	—	DIE CAST ALUM.	DIE CAST ALUM.	—	—	—	—	—	—	—	
16	18	—	—	14	—	—	—			—	—	—	—	—	—	—	—
18	18	—	—	14	—	—	—			—	—	—	—	—	—	—	—
21	18	18	18	14	14	14	16			—	—	14	—	3/4	3/4	1	
24	16	18	16	12	14	14	16			—	14	14	12	3/4	3/4	1	
30	16	18	16	12	12	12	16			—	14	14	12	3/4	1	1	
36	16	18	16	12	12	12	16			—	12	14	12	3/4	1	1	
42	14	16	14	10	12	12	14			—	10	12	10	1	1 ³ / ₁₆	1 ³ / ₁₆	
48	14	16	14	10	12	12	14			—	—	12	10	1	1 ³ / ₁₆	1 ⁷ / ₁₆	
54	—	16	14	—	12	10	14			—	—	12	7	1	1 ³ / ₁₆	1 ⁷ / ₁₆	
60	—	14	14	—	12	10	12	—	—	3/16	7	1 ³ / ₁₆	1 ¹ / ₂	1 ¹¹ / ₁₆			

Outlet Velocities

FAN SIZE	STANDARD DAMPER	HEAVY DUTY DAMPER
	OUTLET VELOCITY	
	MAX. FPM	MIN. FPM
14	2673	2674
16	2540	2541
18	2863	2864
21	2980	2981
24	2619	2620
30	2999	3000
36	3122	3123
42	2828	2829
48	2937	2938
54	2818	2819
60	2907	2908

Backdraft Damper Limits

FAN SIZE	STANDARD DAMPER		HEAVY DUTY DAMPER	
	CFM MAX.	VELOCITY MAX. (FPM)	CFM MAX.	VELOCITY MAX. (FPM)
	14	2960	2673	Not Required
16	3658	2540		
18	5200	2863		
21	7340	2980	7644	3104
24	8400	2619	10932	3408
30	15090	2999	16785	3336
36	22530	3122	25355	3513
42	27700	2828	30777	3143
48	37493	2937	42636	3340
54	45450	2818	53989	3348
60	57800	2907	62829	3160



Direct Drive - WPD

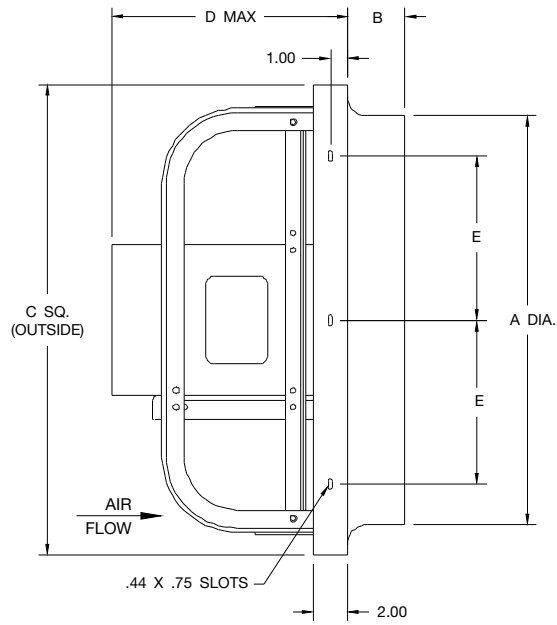

Exhaust Airflow

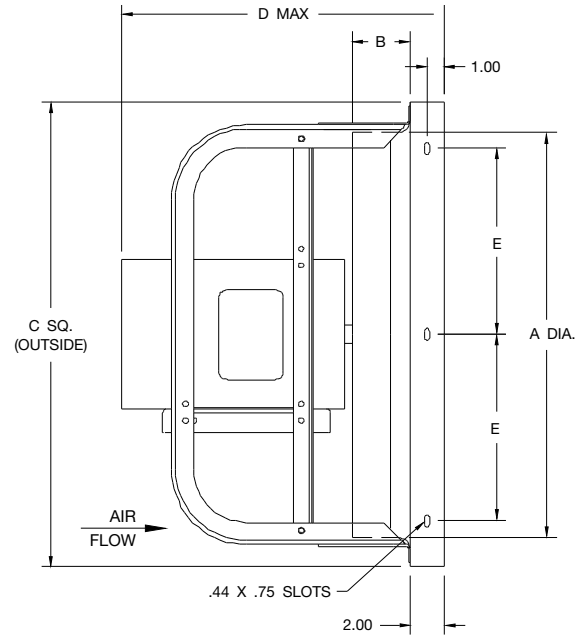

Supply Airflow

SIZE	A	B	C SQ.	D MAX		DAMPER SIZE	MAX MOTOR FRAME
				EXHAUST	SUPPLY		
14	14.25	2.75	17.00	11.18	14.88	14 x 14	56
16	16.25	3.00	20.00	11.18	14.88	17 x 17	56
18	18.25	3.00	22.00	11.18	14.88	19 x 19	56
21	21.25	3.50	25.00	14.41	17.36	22 x 22	145T
24	24.25	3.50	28.00	14.55	17.36	25 x 25	184T
30	30.38	4.00	36.00	14.74	19.05	33 x 33	184T
36	36.38	5.00	42.00	15.67	19.93	39 x 39	215T
42	42.38	5.50	48.00	23.59	30.00	45 x 45	254T
48	48.38	6.00	54.00	23.59	30.00	51 x 51	254T

D4810-12A
D4810-13A



Belt Driven - WPB

Supply Airflow

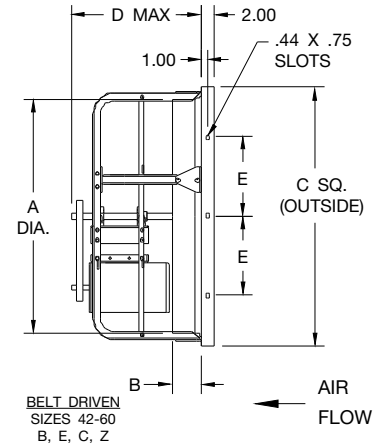
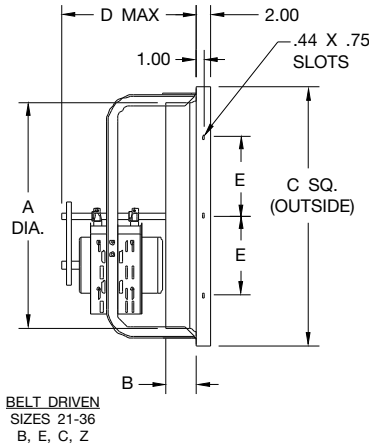
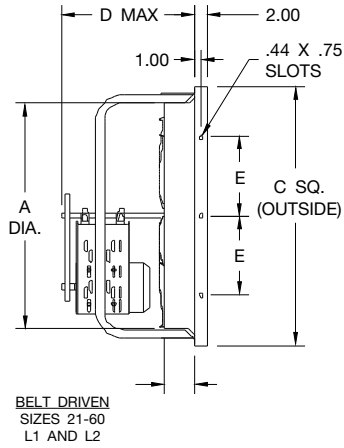

Exhaust Airflow

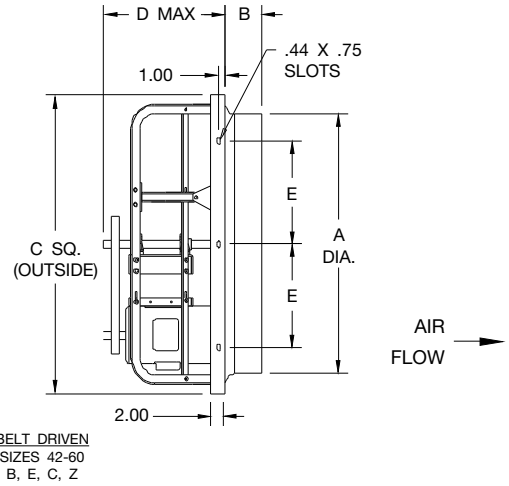
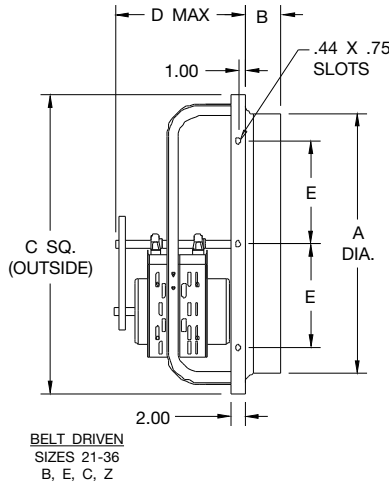
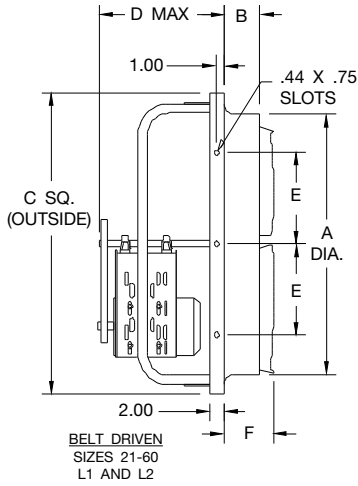

WPB Levels 1 & 2



WPB Level 3 Sizes 21-36



WPB Level 3 Sizes 42-60

SIZE	A	B	C	D MAX						E	F (EXHAUST ONLY)	SHAFT SIZE			MAX MOTOR FRAME			DAMPER SIZE
				EXHAUST			SUPPLY					L1	L2	B, E, C, Z	L1	L2	B, E, C, Z	
				L1	L2	B, E, C, Z	L1	L2	B, E, C, Z									
21	21.25	3.50	25.00	14.19	14.19	17.25	20.00	20.00	20.50	6.75	5.19	.75	.75	1.00	56	145T	145T	22 x 22
24	24.25	3.50	28.00	14.38	14.38	17.25	20.78	20.78	20.50	9.25	5.73	.75	.75	1.00	56	145T	145T	25 x 25
30	30.38	4.00	36.00	15.68	17.06	18.31	22.63	24.25	20.93	11.25	6.87	.75	1.00	1.00	145T	184T	184T	33 x 33
36	36.38	5.00	42.00	16.25	17.44	18.31	22.75	24.32	21.93	13.25	6.57	.75	1.00	1.00	145T	184T	184T	39 x 39
42	42.38	5.50	48.00	16.44	17.94	20.44	23.57	25.00	26.75	15.19	7.44	1.00	1.19	1.19	145T	184T	215T	45 x 45
48	48.38	6.00	54.00	17.06	18.44	20.44	24.75	26.32	26.75	20.58	8.33	1.00	1.19	1.44	145T	184T	215T	51 x 51
54	54.38	6.50	60.00	17.13	18.44	26.13	25.44	26.94	32.30	23.06	9.21	1.00	1.19	1.44	145T	184T	254T	57 x 57
60	60.38	7.25	66.00	17.44	22.68	26.13	26.44	31.82	32.30	25.06	10.11	1.19	1.50	1.69	145T	215T	256T	63 x 63

D4820-12A
D4820-13A

Wall Box with Removable Screen

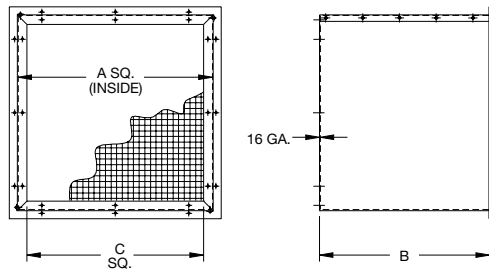

SIZE	A SQ.	B	C SQ.	MINIMUM WALL OPENING
14	17.25	33.50	14.63	18
16	20.25	34.00	17.63	21
18	22.25	34.00	19.63	23
21	25.25	36.00	22.63	26
24	28.25	37.00	25.63	29
30	36.25	40.00	33.63	37
36	42.25	40.00	39.63	43
42	48.25	43.00	45.63	49
48	54.25	43.00	51.63	55
54	60.25	49.00	57.63	61
60	66.25	50.00	63.63	67

D4820-6B

Wall Collar

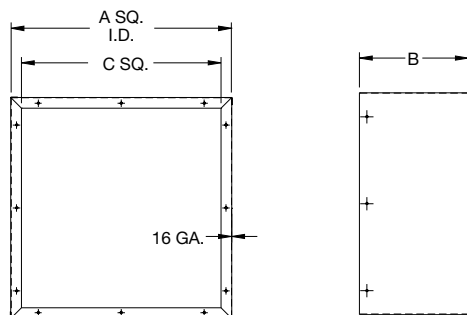

SIZE	A SQ.	B	C SQ.	MINIMUM WALL OPENING
14	17.25	20.00	14.63	18
16	20.25	20.00	17.63	21
18	22.25	20.00	19.63	23
21	25.25	21.00	22.63	26
24	28.25	22.00	25.63	29
30	36.25	23.00	33.63	37
36	42.25	23.00	39.63	43
42	48.25	24.00	45.63	49
48	54.25	25.00	51.63	55
54	60.25	26.00	57.63	61
60	66.25	26.00	63.63	67

D4820-7B

Backdraft Damper

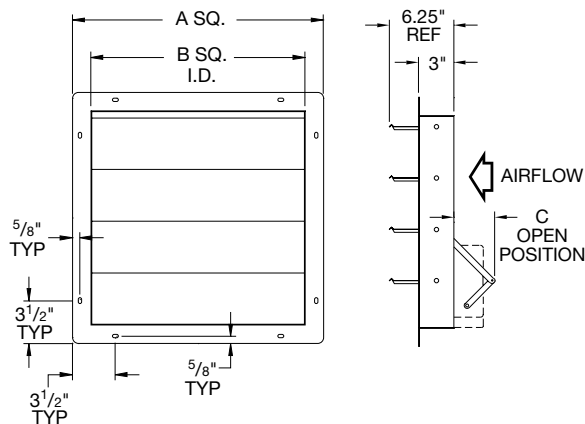

SIZE	A SQ. FLANGE	B SQ.	C	NO. OF PANELS
14	17.00	14	3.50	1
16	20.00	17	3.50	1
18	22.00	19	3.50	1
21	25.00	22	3.50	1
24	28.00	25	3.50	1
30	36.00	33	3.50	1
36	42.00	39	4.50	2
42	48.00	45	4.50	2
48	54.00	51	4.50	2
54	60.00	57	4.50	2
60	66.00	63	4.50	2

Exhaust Damper shown (with front flange).
Supply damper has rear flange.

Weather Hood with Bird Screen

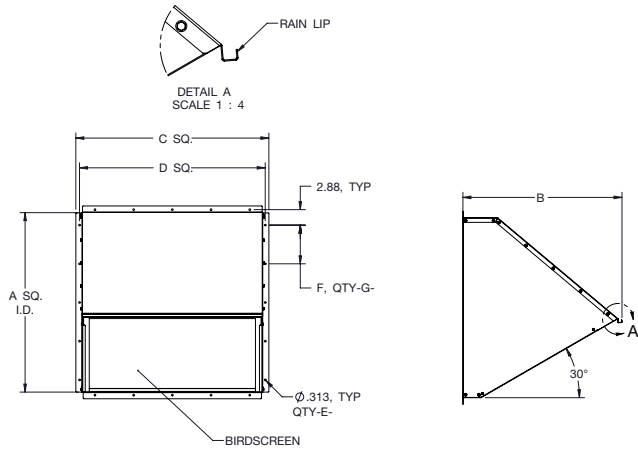

SIZE	A SQ.	B	C		D		GA.
			STD.	EXT.	STD.	EXT.	
14	14.63	16.43	17.13	21.13	15.75	19.75	20
16	17.63	18.43	20.13	24.13	18.75	22.75	20
18	19.63	19.80	22.13	26.13	20.75	24.75	20
21	22.63	22.55	25.13	29.13	23.75	27.75	18
24	25.63	25.68	28.13	32.13	26.75	30.75	18
30	33.63	33.30	36.13	40.13	34.75	38.75	18
36	39.63	40.80	42.13	46.13	40.75	44.75	18
42	45.63	45.93	48.13	52.13	46.75	50.75	18
48	51.63	51.98	54.13	58.13	52.75	56.75	18
54	57.63	56.98	60.13	64.13	58.75	62.75	16
60	63.63	62.98	66.13	70.13	64.75	68.75	16

Standard flange weather hood shown.

D4820-9C

Damper Guard

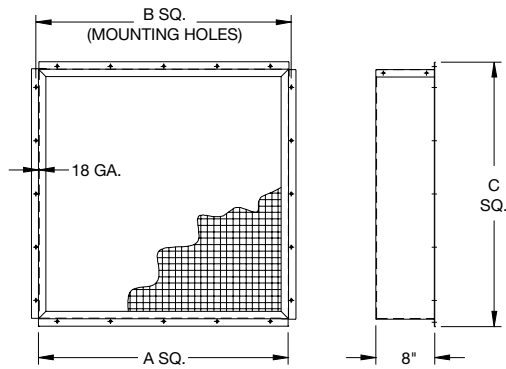

SIZE	A SQ.	B SQ.	C SQ.
14	15	15.75	17
16	18	18.75	20
18	20	20.75	22
21	23	23.75	25
24	26	26.75	28
30	34	34.75	36
36	40	40.75	42
42	46	46.75	48
48	52	52.75	54
54	58	58.75	60
60	64	64.75	66

D4820-5A

OSHA Motor Side Guard

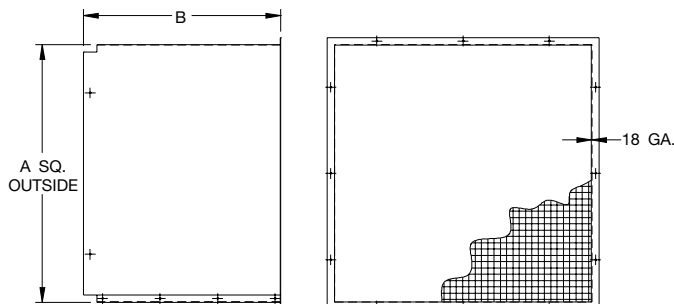

SIZE	A SQ.	B
14	16.84	15.25
16	19.84	15.50
18	21.84	15.50
21	24.84	24.00
24	27.81	24.50
30	35.81	28.00
36	41.81	28.00
42	47.81	31.50
48	53.81	31.50
54	59.81	36.00
60	65.81	36.00

D4820-10B



Model

WPD

Wall Mounted Fans shall be Model WPD direct drive as manufactured by Twin City Fan & Blower, Minneapolis, Minnesota.

PERFORMANCE - Fans shall be tested in accordance with AMCA 210 and AMCA 300 test codes for air moving devices and shall be guaranteed by the manufacturer to deliver rated published performance levels. Fans shall be licensed to bear the AMCA certified ratings seal for both sound and air.

CONSTRUCTION - Fan panels and motor mount assemblies shall be constructed of heavy gauge steel for durability and appearance. Panels shall have a deep formed inlet venturi and pre-punched holes for easy mounting.

IMPELLERS - Impellers shall be constructed of fabricated steel or cast aluminum blades and hubs. Impellers on direct drive units shall be mounted directly on the motor shaft with a taper lock bushing. Impellers on belt driven units shall be welded to the fan shaft or secured with a taper lock bushing.

MOTORS - All motors shall be split phase and capacitor start single phase or three phase induction, permanently lubricated, heavy-duty, ball bearing type, closely matched to the fan load and provided at the voltage, phase, hertz and enclosure as provided on the fan schedule.

FINISH AND COATING - The entire fan assembly, excluding the shaft, shall be properly washed and pretreated before application of a rust-preventative primer, if called out on the order. After the fan is completely assembled, a finish coat of paint shall be applied to the entire assembly, if called out on the order. The fan shaft shall be coated with a petroleum-based rust protectant.

ACCESSORIES - When specified, accessories such as wall boxes, wall collars, OSHA motor side guards, weather hoods, backdraft dampers, damper guards and disconnect switches shall be provided by Twin City Fan to maintain one source responsibility.

FACTORY RUN TEST - All fans prior to shipment shall be completely assembled and test run as a unit at operating speed or maximum RPM allowed for the particular construction type. Each impeller shall be statically and dynamically balanced in accordance with ANSI/AMCA 204-96 "Balance Quality and Vibration Levels for Fans" to Fan Application Category BV-3, Balance Quality Grade G6.3. Balance readings shall be taken by electronic type equipment in the axial, vertical and horizontal directions on each of the bearings. Records shall be maintained and a written copy shall be available upon request.

GUARANTEE - The manufacturer shall guarantee the workmanship and materials for its WPD wall mounted fans for at least one (1) year from startup or eighteen (18) months from shipment, whichever occurs first.





Model WPB

Wall Mounted Fans shall be Model WPB belt driven as manufactured by Twin City Fan & Blower, Minneapolis, Minnesota.

PERFORMANCE - Fans shall be tested in accordance with AMCA 210 and AMCA 300 test codes for air moving devices and shall be guaranteed by the manufacturer to deliver rated published performance levels. Fans shall be licensed to bear the AMCA certified ratings seal for both sound and air.

CONSTRUCTION - Fan panels and motor mount assemblies shall be constructed of heavy gauge steel for durability and appearance. Panels shall have a deep formed inlet venturi and pre-punched holes for easy mounting.

IMPELLERS - Impellers shall be constructed of fabricated steel or cast aluminum blades and hubs. Impellers on direct drive units shall be mounted directly on the motor shaft with a taper lock bushing. Impellers on belt driven units shall be welded to the fan shaft or secured with a taper lock bushing.

SHAFTS - Shafts shall be AISI 1045 cold rolled steel, accurately turned, ground, polished and ring-gauged for accuracy. Shafts shall be sized for the first critical speed of at least 1.43 times the maximum speed.

BEARINGS - Bearings are to be pillow block, heavy-duty, anti-friction, self-aligning, grease lubricated, ball type. Each fan's bearings are sized with a minimum average life, per AFBMA, in excess of 200,000 hours when operating at the maximum RPM of the class.

DRIVES - Motor sheaves shall be cast iron and supplied as variable pitch standard. Drives and belts shall be rated for a minimum of 150% of the required motor HP.

MOTORS - All motors shall be split phase and capacitor start single phase or three phase induction, permanently lubricated, heavy-duty, ball bearing type, closely matched to the fan load and provided at the voltage, phase, hertz and enclosure as provided on the fan schedule.

FINISH AND COATING - The entire fan assembly, excluding the shaft, shall be properly washed and pretreated before application of a rust-preventative primer, if called out on the order. After the fan is completely assembled, a finish coat of paint shall be applied to the entire assembly, if called out on the order. The fan shaft shall be coated with a petroleum-based rust protectant.

ACCESSORIES - When specified, accessories such as wall boxes, wall collars, OSHA motor side guards, weather hoods, backdraft dampers, damper guards and disconnect switches shall be provided by Twin City Fan to maintain one source responsibility.

FACTORY RUN TEST- All fans prior to shipment shall be completely assembled and test run as a unit at operating speed or maximum RPM allowed for the particular construction type. Each impeller shall be statically and dynamically balanced in accordance with ANSI/AMCA 204-96 "Balance Quality and Vibration Levels for Fans" to Fan Application Category BV-3, Balance Quality Grade G6.3. Balance readings shall be taken by electronic type equipment in the axial, vertical and horizontal directions on each of the bearings. Records shall be maintained and a written copy shall be available upon request.

GUARANTEE - The manufacturer shall guarantee the workmanship and materials for its WPB wall mounted fans for at least one (1) year from startup or eighteen (18) months from shipment, whichever occurs first.



INDUSTRIAL PROCESS AND COMMERCIAL VENTILATION SYSTEMS

CENTRIFUGAL FANS | UTILITY SETS | PLENUM & PLUG FANS | INLINE CENTRIFUGAL FANS
MIXED FLOW FANS | TUBEAXIAL & VANEAXIAL FANS | WALL MOUNTED FANS | ROOF VENTILATORS
CENTRIFUGAL ROOF & WALL EXHAUSTERS | CEILING VENTILATORS | GRAVITY VENTILATORS | DUCT BLOWERS
RADIAL BLADED FANS | RADIAL TIP FANS | HIGH EFFICIENCY INDUSTRIAL FANS | PRESSURE BLOWERS
LABORATORY EXHAUST FANS | FILTERED SUPPLY FANS | MANCOOLERS | FIBERGLASS FANS | CUSTOM FANS



TWIN CITY FAN & BLOWER
WWW.TCF.COM

5959 TRENTON LANE N. | MINNEAPOLIS, MN 55442 | PHONE: 763-551-7600 | FAX: 763-551-7601

©2005-2024 Twin City Fan Companies, Ltd., Minneapolis, MN. All rights reserved. Catalog illustrations cover the general appearance of Twin City Fan & Blower products at the time of publication and we reserve the right to make changes in design and construction at any time without notice.