



# CENTRIFUGAL POWERED ROOF & WALL EXHAUSTERS

INSTALLATION, OPERATION & MAINTENANCE MANUAL



## REVIEW AMCA BULLETIN 410 PRIOR TO INSTALLATION

This manual has been prepared to guide the users of centrifugal powered roof and wall exhausters in the proper installation, operation and maintenance procedures to ensure maximum equipment life with trouble-free operation. For safe installation, startup and operational life of this equipment, it is important that all involved with the equipment be well versed in proper fan safety practices and read this manual. It is the user's responsibility to make sure that all requirements of good safety practices and any applicable safety codes are strictly adhered to. Because of the wide variety of equipment covered in this manual, the instructions given here are general in nature. Additional product and engineering information is available at [www.tcf.com](http://www.tcf.com).

### SAFETY NOTICE

Refer to the Safety section(s) in this manual prior to installing or servicing the fan. The most current version of this installation and maintenance manual can be found on our website at [www.tcf.com/resources/im-manuals](http://www.tcf.com/resources/im-manuals).

### TABLE OF CONTENTS

Exploded View.....	2	Drive Mounting.....	12
Impeller Nomenclature & Type .....	2	Three-Pulley Assembly.....	12
Impeller Rotation .....	3	V-Belts .....	13
Receiving, Inspection & Unpacking .....	3	Check, Test & Start Procedure .....	14
Safety & Hazard Warnings .....	3-4	Maintenance .....	15-16
Unit Storage .....	4-5	Motor Lubrication .....	16
Hood Lifting Instructions.....	5	Duct Connections.....	16
Handling.....	6	Optional Accessories.....	17-18
Shipment of Motors.....	7	Serial Number & Fan Type Nameplate .....	18
General Installation.....	7	Accessory Installation Instructions .....	19-23
Wall Fan Installation.....	7	Troubleshooting Guidelines .....	24
Fan Installation .....	8	Installation / Start-up Checklist.....	25
Roof Fan Installation .....	9	Fan Maintenance Log.....	26-27
Electrical Connection .....	9		
EC Motor Information.....	10		
Bearing Installation .....	10		
Safety & Bearing Lubrication Instructions .....	10		
Speed Control Installation.....	11		



# EXPLODED VIEW AND IMPELLER NOMENCLATURE/TYPE

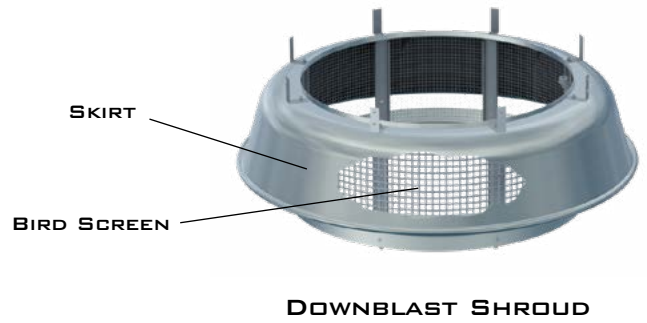
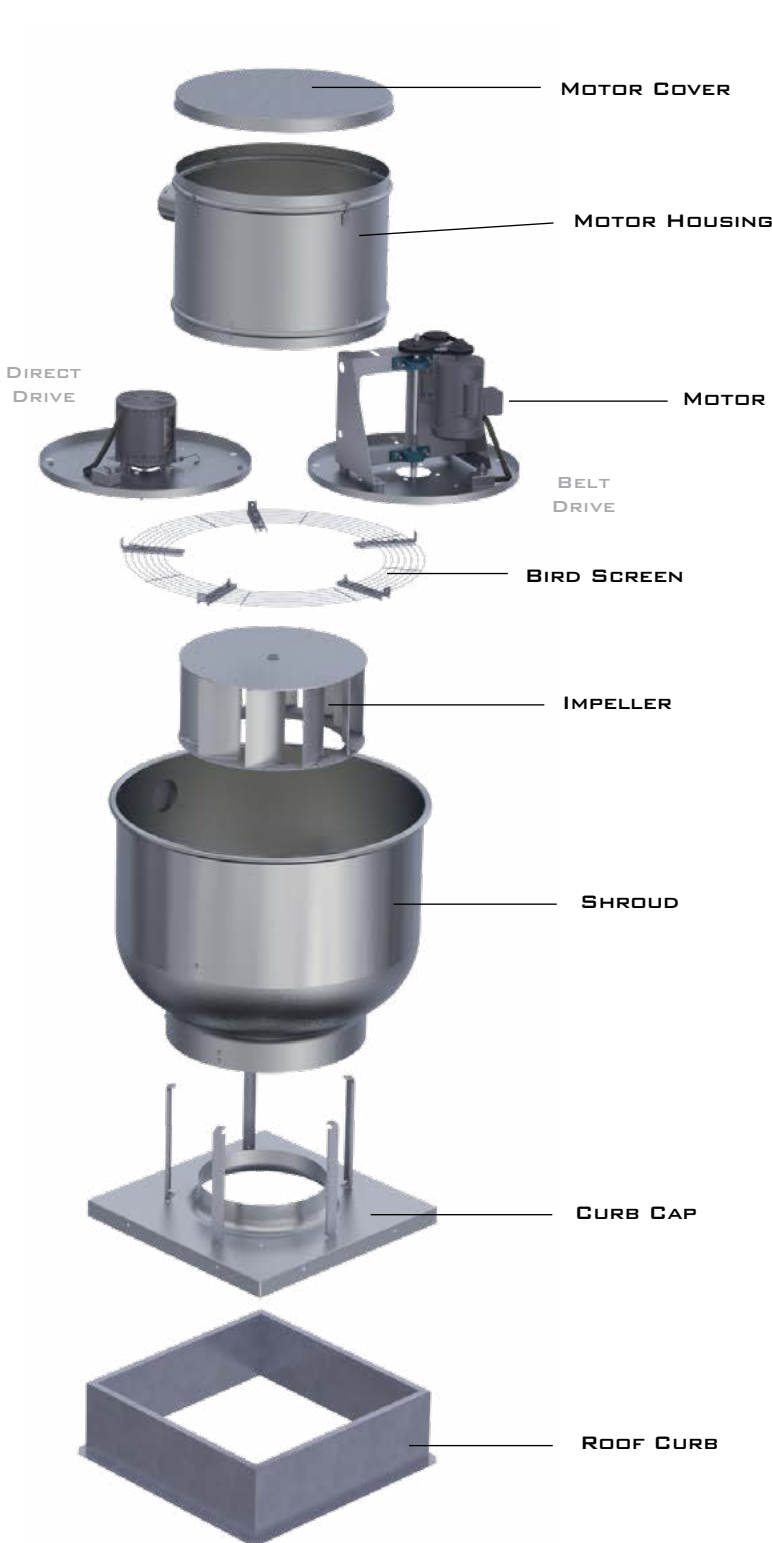

## IMPELLER INFORMATION

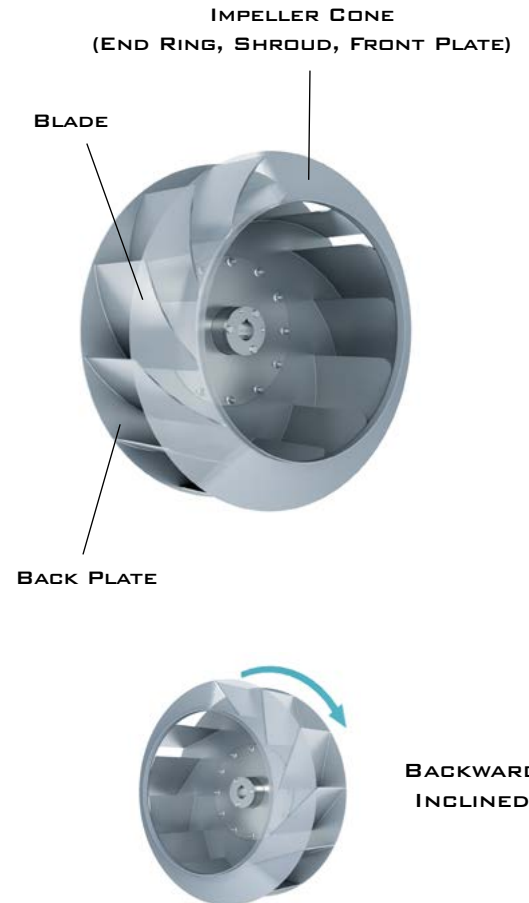

## IMPELLER ROTATION

### ROTATION VIEW FROM DRIVE SIDE

#### COUNTER-CLOCKWISE (CCW) EXAMPLE SHOWN



## RECEIVING, INSPECTION & UNPACKING

When the equipment is received all items should be carefully checked against the bill of lading to be sure all crates and cartons have been received. Before accepting delivery, carefully inspect each carton or crate for visible shipping damage. If any damage is noticed, the carrier should make the proper notation on the delivery receipt acknowledging the damage. Make notations of all damage on all copies of the bill of lading and have all copies countersigned by the delivering carrier. The carrier should also fill out a Carrier Inspection Report. The factory Traffic Department should then be contacted. File claim for damage with the carrier. Physical damage to the unit after acceptance is not the responsibility of Twin City Fan Companies, Ltd.

Unpack each carton or crate and verify that all required parts and proper quantities of each item have been received. Refer to drawings for part descriptions. Report shortages or missing items to your local representative to arrange for replacement parts. Due to availability of carriers and truck space, it is not possible to guarantee that all items will be shipped together. Verification of shipments must be limited to only those items on the bill of lading.

**The unit nameplate must be checked to make sure the voltage agrees with the power supply available.**

## SAFETY & HAZARD WARNINGS

For general safety practices for air moving equipment, see AMCA Bulletin 410. Twin City Fan offers many safety accessories. These safety devices include (but are not limited to) Firestat, inlet and discharge screens. The use and suitability of safety devices is the responsibility of the purchaser.

Facility related safety conditions include fans' accessibility and location. How easily can non-service personnel access the unit? Is the fan in a hazardous duty environment? Was the unit ordered for this duty? Other concerns must also be addressed. All fans should be powered through switches that are easily accessible to service personnel from the fan. Fan power must have the ability to be "locked out" by service personnel trained in lockout/tagout procedures per OSHA requirements (29CFR1910.147). When performing lockout, be aware of factors, such as building pressure and additional fans in the system that can influence unwanted fan rotation (wind milling). If you have any doubt about your ability to perform a task, seek a person qualified to do that task. Before any work is done on a fan, ensure that the fan is isolated from the electrical supply using a 'lockout/tagout system.'

## SAFETY & HAZARD WARNINGS (CONT.)

Note: A stationary, non-rotating fan does not mean that the fan is isolated from the electrical supply. A non-rotating fan could be subject to controls or other circuit protection devices that may start the fan without notice.

The following safety precautions should be followed, where applicable:

- Do not attempt to slow a rotating impeller even when it is isolated from the electrical supply. Fan impellers have a high inertia and injury could result from an attempt to stop it. It is recommended that the impeller is isolated by closing off the inlet or outlet to prevent wind-driven rotation. If an impeller is chocked to prevent rotation, ensure that the chocks are removed prior to start up.
- Wear appropriate personal protective equipment. This may include protective clothing, eye protection, ear protection, respiratory equipment, hand and foot protection when installing or servicing the fan.
- Always use caution when entering a fan's air path. High velocity airflow can cause you to lose your balance.
- Motor, bearings and drives can be hot, and similarly if the fan is subject to processes that are hot, the fan housing could be hot.
- Fans are often used to move hazardous materials that could be dangerous. Always wear protective clothing and take precautions not to inhale dust/gases. If hazardous chemical vapors are present, respiratory equipment may be required.
- Sharp edges – wear protective gloves when handling, installing or servicing a fan.
- Fans can operate at high decibel sound levels. Wear proper ear protection to protect from excessive noise levels.
- Access Doors – Do not open access doors when fan is in operation. The effects of suction and air pressure could result in injury.
- When working around pulleys and belts, keep hands away from pinch points. This pertains to when the fan is under or off power.

Throughout this manual, there are a number of HAZARD WARNINGS that must be read and adhered to in order to prevent possible personal injury and/or damage to equipment. Two signal words "WARNING" and "CAUTION" are used to indicate the severity of a hazard and are preceded by the safety alert symbol. It is the responsibility of all personnel involved in installation, operation and maintenance to fully understand the warning and caution procedures by which hazards are to be avoided.

 **WARNING:** Used when serious injury or death MAY result from misuse or failure to follow specific instructions.

 **CAUTION:** Used when minor or moderate injury or product / equipment damage MAY result from misuse or failure to follow specific instructions.

**NOTICE:** Indicates information considered important, but not hazard-related.

---

## UNIT STORAGE

If fan installation is to be delayed, store the unit in an environmentally stable and protected area. During storage, the fan should not be subjected to vibration from external sources or bearing damage may occur. The unit should be reasonably protected from any accidental impacts. Cover the fan to protect coatings and to prevent any foreign material or moisture from entering the inlet or discharge. Take care to protect the motor, drives and bearings.

Extended storage requires monthly inspections. Check for corrosion or damage to the unit and for debris within the fan.

Bearings tend to take on moisture if the atmosphere in which they are stored is not at a constant temperature. To avoid corrosion, it is necessary to keep the bearings full of grease and to rotate them periodically. Even when full of grease, bearings will take on moisture, so it is necessary to purge the bearings with new grease to expel moisture every thirty days. It is recommended that the bearings be purged with grease while being rotated by hand. Do not use high pressure greasers as they may ruin the bearing seals. Remove old/excess grease and regrease the bearing in accordance with the bearing manufacturer's instructions.

The drives and belts should be removed if the fan is to be stored for a prolonged period. The drives should be labeled for service and stored in a dry place. Belts should be removed, coiled without kinks, placed in a heavy carton and stored in a dry, well-ventilated place. To prevent belt deterioration storage conditions should not exceed 85°F and 70% humidity. If belts show signs of deterioration, they should be replaced prior to startup.

**UNIT STORAGE (CONT.)**

Motors should be stored in a clean, dry, vibration-free location. The packaging should be opened up enough to allow air circulation around the motor. The winding temperature should be kept slightly above that of the surroundings to prevent condensation. This can be accomplished by energizing the internal heaters, if the motor is so equipped, or by using space heaters. If it is impossible to heat the windings, the motor should be wrapped tightly with a waterproof material that also encloses several bags of desiccant. Replace the desiccant regularly to prevent moisture problems. The motor rotor should also be rotated regularly (monthly) to assure the bearing parts are well greased. Shafts on motors equipped with shaft grounding rings must remain rust free. Failure to do so renders the grounding feature inoperative and may result in bearing failure under VFD operation. Consult the motor manufacturer for further detail on motor storage and start up after longer periods of storage. It may be necessary to regrease the bearings. If the fan's bearings or motor bearings have extended lubrication lines, it will be necessary to replace the grease by detaching from the motor/bearing and purging the line with new grease.

**HOOD LIFTING INSTRUCTIONS (BCLH, DCLH, BCLP, DCLP)**

Fan assembly and hood assembly are to be lifted separately.

**Fan assembly** – Attach chains (with spreader bars) to hood mount bars at four places.

**Hood assembly** – Attach chains (with spreader bars) to clevis/mounting lug on hood side rail at four places.

*Lifting Arrangement*

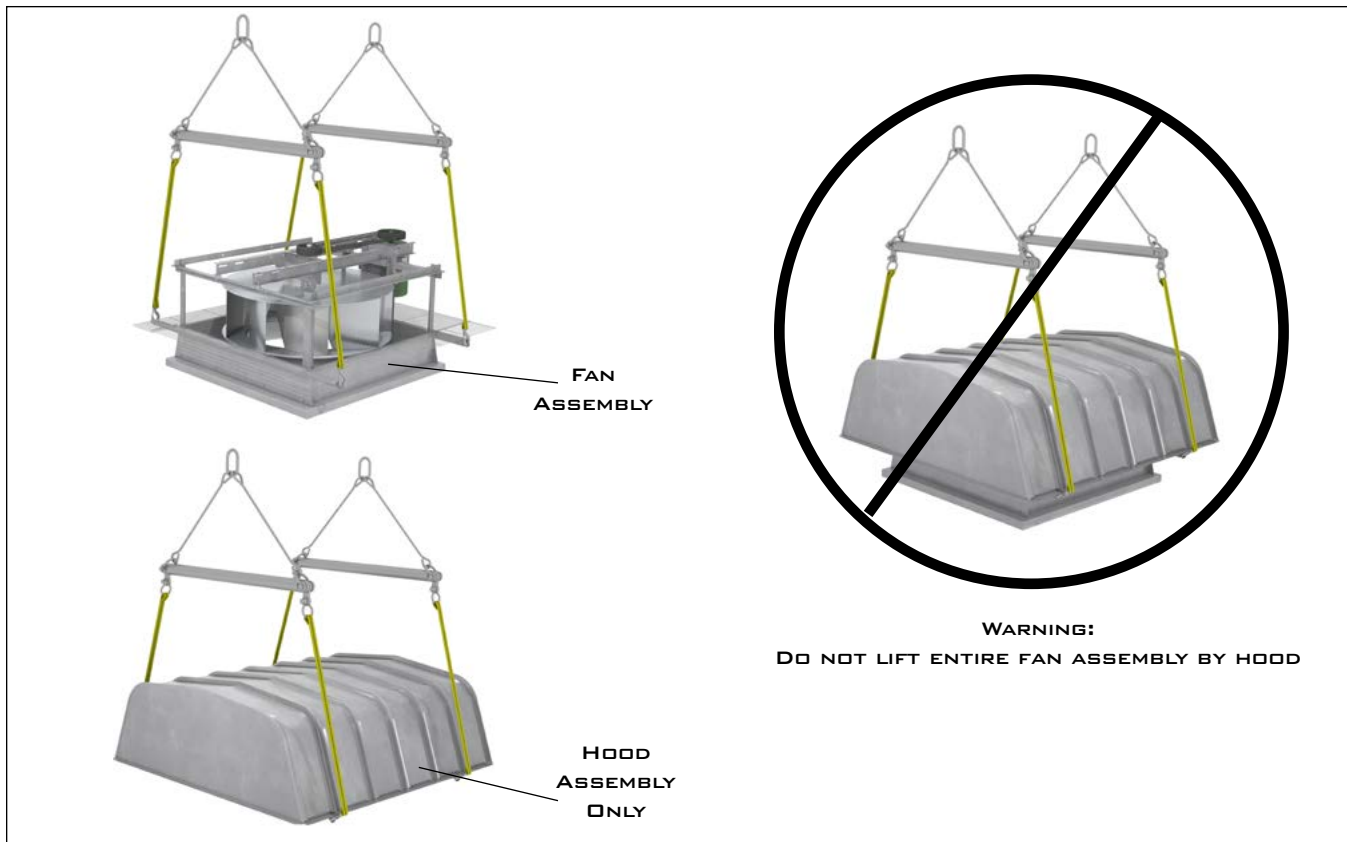



## HANDLING

Handling of all air moving equipment should be conducted by trained personnel and be consistent with safe handling practices. Verify the lift capacity and operating condition of handling equipment. When using hoisting equipment, only qualified and trained personnel should operate the equipment.

Units shipped completely assembled may be lifted with slings and spreader bars. (Use well-padded chains, cables or nylon straps, rated to lift the required weight.) On most units, lifting lugs are designed to protect the fan and fan housing from damage. Never lift a fan by the inlet or discharge flange, shafting or drives, impeller, motor or motor base, or in any other manner that may bend or distort parts. Never lift with slings or timbers passed through the fan inlets.

For fans provided without lifting lugs, use a forklift or pallet jack to handle the equipment. Consult a qualified person before lifting.



### CAUTION

1. Maintain handling equipment to avoid serious personal injury and do not stand under the load.
2. If supplied, only use the provided lifting lugs to lift the equipment.
3. Ensure that the lifting equipment is rated for the capacity to be lifted.

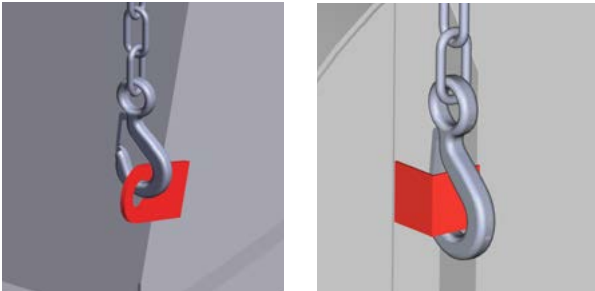

*Lifting lugs are provided on most units.*

*Motor support brackets in upblast units have two large holes for hooks in order to lift properly*

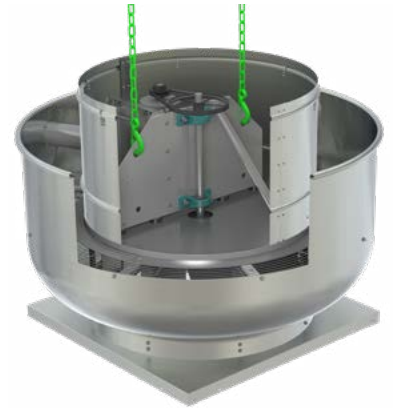

## SHIPMENT OF MOTORS

Larger motors will ship loose in order to prevent shipping damage, per the following charts.

### BCRD, BCLH, BCLP

SIZE	SHIP MOTOR LOOSE
070D – 160D 100HP – 160HP	<ul style="list-style-type: none"> <li>Motor HP larger than shown on TCF&amp;B Price List P-4105</li> </ul>
180D – 240D 180HP – 210HP	<ul style="list-style-type: none"> <li>143T and larger – ODP/TE Cast iron frames</li> <li>145T and larger – ODP/TE Rolled frames</li> <li>143T and larger – Explosion-proof motors</li> </ul>
300D – 360D 240HP – 300HP	<ul style="list-style-type: none"> <li>182T and larger – ODP/TE Cast iron frames</li> <li>184T and larger – ODP/TE Rolled frames</li> <li>182T and larger – Explosion-proof motors</li> </ul>
420D – 480D 360HP, 540	<ul style="list-style-type: none"> <li>184T and larger – ODP/TE Cast iron frames</li> <li>213T and larger – ODP/TE Rolled frames</li> <li>184T and larger – Explosion-proof motors</li> </ul>

### BCRU, BCRUR, BCRUSH, BCRW, BCRWR

SIZE	SHIP MOTOR LOOSE
110B – 160B 140HP – 160HP	<ul style="list-style-type: none"> <li>143T and larger – ODP/TE Cast iron frames</li> <li>145T and larger – ODP/TE Rolled frames</li> <li>143T and larger – Explosion-proof motors</li> </ul>
180B – 240B 180HP	<ul style="list-style-type: none"> <li>145T and larger – ODP/TE Cast iron frames</li> <li>182T and larger – ODP/TE Rolled frames</li> <li>145T and larger – Explosion-proof motors</li> </ul>
300B – 360B 210HP – 300HP	<ul style="list-style-type: none"> <li>182T and larger – ODP/TE Cast iron frames</li> <li>184T and larger – ODP/TE Rolled frames</li> <li>182T and larger – Explosion-proof motors</li> </ul>
420B – 480B 360HP	<ul style="list-style-type: none"> <li>184T and larger – ODP/TE Cast iron frames</li> <li>213T and larger – ODP/TE Rolled frames</li> <li>184T and larger – Explosion-proof motors</li> </ul>

## GENERAL INSTALLATION

The installation of this equipment shall be in accordance with the regulations of authorities having jurisdiction and all applicable codes.

This equipment is to be installed by an experienced installation company and fully trained personnel.

The mechanical installation of the exhaust ventilator consists of making final connections between the unit and building services, duct connections.

**CAUTION**

Sheet metal parts, screws, clips and similar items inherently have sharp edges and it is necessary that the installer and service personnel exercise caution.



## WALL FAN INSTALLATION (REFER TO LIFTING/SAFETY SECTION)

1. Your wall fan is shipped with a wall mounting bracket. Consideration should be taken when choosing wall fan location with regard to other buildings, parking lots, etc.
2. After drilling pilot holes, bolt the wall mounting bracket to the wall through the holes provided on the bracket flange using eight (8) lag bolts.
3. Position fan with the motor compartment breather tube facing downward.

**NOTICE**

On Models BCRWR and DCRWR, the breather tube can be facing downward or towards either side. Do not install with breather tube facing up.

4. Run wires through conduit to switch. Leave some slack in the wire in the motor compartment so that the motor and impeller assembly can be lifted for inspection and cleaning. If fan has an external disconnect switch (standard on restaurant units) bring power to switch.
5. Bolt the fan base to the wall bracket using hardware provided.
6. Make connection to the disconnect switch per above electrical instructions.
7. Restaurant fan installation must be in compliance with local codes and the National Fire Protection Association's NFPA-96.
8. Models DCLH, DCLP, DCRD, DCRU, DCRUR, BCLH, BCLP, BCRD, BCRU, BCRUR and BCRUSH are not designed to be mounted to a wall.

## FAN INSTALLATION (REFER TO LIFTING/SAFETY SECTION)

All fan impellers are statically and dynamically balanced using state of the art equipment in the factory. Final trim balancing is performed on factory assembled fans, unless the specified electrical characteristics of the motor are outside the limits of the factory test equipment. If the motor and drives are supplied, the complete assembly is run tested and balanced. Infrequently, fans are supplied with unusual electrical characteristics and cannot be tested with the motor. In this situation the fans are run and balanced using a factory driver. Likewise, if motors and/or drives are not supplied, the fan is tested with the factory driver. Final balancing, at the buyer's expense, should be performed in the field after the motor and/or drives are installed. This service is available from TCF, otherwise this should be entrusted to a qualified technician.

Follow proper handling instructions as given earlier.

1. Move the fan to the final mounting position.
2. Remove skid, crates and packing materials carefully.
3. Place the fan on mounting structure. Carefully level the unit (checking the level on the shaft).
4. Check the alignment of the bearings. Shim or reposition the bearings if necessary.
5. Check alignment of sheaves on belt driven fans.
6. Check tension of belts to see if it is sufficient. Sheaves on belt driven fans are often provided with taper lock bushings. When tightening bushing bolts, proceed in a progressive manner to avoid cocking the tapered surfaces between the bushing and the sheave. Torque per tables below.

**CLICK TO VIEW OUR  
SHEAVE INSTALLATION VIDEO**

7. Check the tightness of the impeller on the shaft. Check the tightness of foundation bolts, motor bolts, sheaves and bearings. Make sure there is no rubbing or binding and that the impeller-inlet cone clearances and overlap are correct.
8. Check that bearings are fully lubricated and check the oil level in the static oil lube systems.
9. Install any accessories shipped loose from the factory.

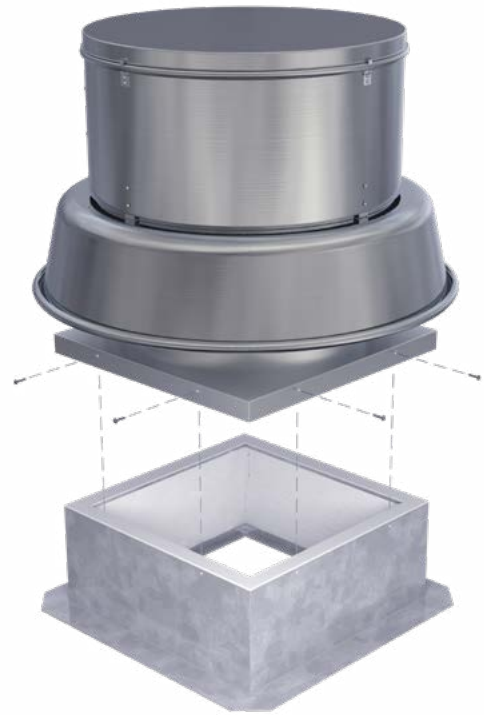

*Carefully level the fan on the foundation*

### TIGHTENING TORQUE

SIZE	FASTENER - TIGHTENING TORQUE (Ft. Lbs.)		
	GRADE 2	GRADE 5	GRADE 8
#10	—	—	—
1/4-20	5.5	8	12
5/16-18	11	17	25
3/8-16	22	30	45
7/16-14	30	50	70
1/2-13	55	75	110

SIZE	TAPER BUSHINGS - TIGHTENING TORQUE (Ft. Lbs.)		
	SPLIT		QD FOR DRIVE
	IN IRON	IN ALUM. HUB	
#10	—	—	6
1/4-20	7.9	7.5	9
5/16-18	16	13	15
3/8-16	29	24	30

The above torque values are for nonlubricated fasteners and Browning Bushings. For bearing set screws, use manufacturer's recommendations. If other bushings are used, utilize bushing manufacturer's specifications.

Tolerance: +/- 5%

For impeller set screws use Grade 2 values.

## ROOF FAN INSTALLATION (REFER TO LIFTING/SAFETY SECTION)

### Downblast/Hooded Fans:

1. Position the fan with its wiring conduit in line with the wiring coming up through the roof curb and damper (if present). If the fan has an external disconnect switch, position the fan with the junction box towards the power supply.
2. Run wires through the conduit to the switch. Leave some slack in the wire in the motor compartment so the motor and impeller assembly can be lifted for inspection and cleaning.
3. Bolt the fan base to the roof curb through the holes provided on the base using eight (8) lag bolts.
4. Make connection to the disconnect switch per above electrical instructions.

### Upblast Fans:

1. Position the fan with its wiring conduit, coming through the outer fan housing or its external disconnect, towards the power supply.
2. Run wires through the conduit to the switch. Leave some slack in the wire in the motor compartment so the motor and impeller assembly can be lifted for inspection and cleaning.
3. Bolt the fan base to the roof curb through the holes provided on the base using eight (8) lag bolts.
4. Make connection to the disconnect switch per above electrical instructions.
5. Restaurant and smoke evacuation fan installation must be in compliance with local codes and the National Fire Protection Association's NFPA-96.



## ELECTRICAL CONNECTION

1. Connect supply wiring to the disconnect switch (non-fused standard). Check the wiring diagrams on the motor for connections.
2. The motor is factory set at the voltage marked on the fan nameplate. Check the line voltage with the nameplate voltage and wiring diagrams.
3. The main power wiring should be sized for the ampacity shown on the dataplate. Size wires in accordance with the ampacity tables in Article 310 of the National Electrical Code. If long wires are required, it may be necessary to increase wire size to prevent excessive voltage drop. Wires should be sized for a maximum of 3% voltage drop.
4. Disconnect switches are not fused. The power leads must be protected at the point of distribution in accordance with the fan dataplate.
5. On fans without a thermal protector integral to the motor (refer to unit or motor dataplate to determine if protector is present) a separate overload device is required. Refer to Sections 430-32 of the N.E.C. for sizing.
6. All units must be electrically grounded in accordance with local codes or, in the absence of local codes, with the latest edition of the National Electrical Code (ANSI/NFPA 70). A ground lug is provided as standard in the unit terminal box. Size grounding conductor in accordance with Table 250-95 of the National Electrical Code. DO NOT use the ground lug for connecting a neutral conductor.
7. Supply voltage to the power ventilator should not vary by more than 10% of the value indicated on the unit dataplate. Phase unbalance must not exceed 2%.



### CAUTION

1. Use copper conductors only.
2. Protect wiring from sharp edges. Leave some slack in the line to prevent damage.



### WARNING

Failure of motor due to operation on improper line voltage or with excessive phase unbalance constitutes product abuse and may cause severe damage to the unit's electrical components.

## EC MOTOR INFORMATION

See [Single-Phase EC Motors Manual, IM-4055](#) for EC motor details.

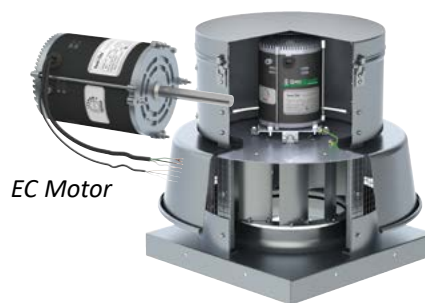

EC Motor

## BEARING INSTALLATION (REFER TO SAFETY SECTION)

This section gives some general instructions on bearing installation. If bearings are to be field installed, the specific installation manual for the bearings will be provided and should be followed carefully. If provided, check the assembly drawings and bearing manufacturer's instructions for location of the fixed and expansion bearings. The positions of these bearings cannot be interchanged. Always follow the bearing manufacturer's instructions.

### Solid Pillow Block

1. Lightly lubricate the bearing bore and slide bearing into the proper position on the shaft. Sling the rotor assembly into place and loosely bolt the bearings in place.
2. When bearings are in place, shim appropriately and torque the base bolts using values from the Tightening Torque table on page 8. Tighten the collar set screws to manufacturer's specification. The set screws on both bearings should be aligned with one another.
3. Unless the user orders differently, bearings are lubricated in the factory with a lithium complex, NLGI grade 2 grease. **Refer to the bearing lubrication schedule below.**



Solid Pillow Block Bearings

## SAFETY & BEARING LUBRICATION INSTRUCTIONS



### WARNING

1. This equipment must not be operated without proper guarding of all moving parts. While performing maintenance be sure remote power switches are locked off. See installation manual for recommended safety practices.
2. Before starting: Check all set screws for tightness and rotate impeller by hand to make sure it has not moved in transit.



### Fans with Ball Bearings

Shaft DIA	Relubrication Schedule (Weeks)*								
	Ball Bearing Pillow Blocks								
	Speed (RPM)								
	500	1000	1500	2000	2500	3000	3500	4000	4500
1/2" thru 1 11/16" (13 - 45)	6	6	5	3	3	2	2	2	1

\*Suggested lubrication interval under continuous operation in adverse loading or with elevated temperatures. For operation less than 24 hours per day or under ideal conditions, lubrication frequency may be reduced. Relubricate while running, if safety permits, until some purging occurs at seals. Adjust lubrication frequency depending on condition of purged grease. Hours of operation, temperature and surrounding conditions will affect the relubrication frequency required.

1. Lubricate with a high quality NLGI No. 2 lithium-base grease having rust inhibitors and antioxidant additives, and a minimum oil viscosity of 500 SUS at 100°F (38°C). Some greases having these properties are:  
 Shell - Gadus S2 V100 2  
 Mobil - Mobilith SHC100  
 Mobil - Ronex MP  
 Mobil - Mobilith SHC220
2. Lubricate bearings prior to extended shutdown or storage and rotate shaft monthly to aid corrosion protection
3. Any lubrication requirements noted on the general assembly drawing supersede requirements found here.

## SPEED CONTROL INSTALLATION

(MODELS DCLH, DCLP, DGRD, DGRU, DGRUR, DGRW, DGRWR - OPTIONAL)

When the controller is shipped loose, it can be installed externally, or alternatively it can be installed inside of the fan 90 degrees from the disconnect switch. Speed control is available using 115/60/1 open type PSC or shaded pole motors. Connect control in series with motor and line voltage (115V only). Never connect across line. See Connection Diagram.

### Minimum Speed Setpoint

All controls are factory set to 65V±3V output as standard with an input voltage of 120V. If different minimum speed is desired, the control may be adjusted by turning minimum speed pot clockwise to decrease minimum speed and counterclockwise to increase minimum speed. Refer to Low End Setpoint Adjustment figure.

TYPICAL SPEED CONTROL INSTALLATION LOCATION



Connection Diagram, Speed Control

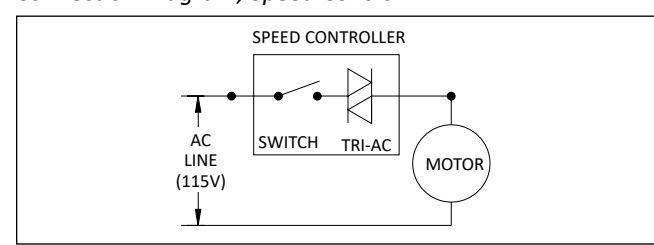

One red wire will be connected to the AC line voltage. The second red wire will be connected to the input power lead for the motor. The green wire is the ground wire.

**WARNING**

1. If minimum speed is readjusted, verify unit ampere draw does not exceed motor nameplate amps. Do not operate unit in range where amp draw exceeds motor nameplate.
2. Certain failure modes of solid-state controls such as half-waving can cause high levels of DC, motor overheating and motor burn-out. Therefore, a thermal overload protection (integral with motor) is required to limit the maximum motor temperature under such a failure.

**CAUTION**

These motors operate more efficiently in the ranges set from the factory. Operating motor outside these ranges (see Speed Controller RPM Range table) may cause motor to run hotter and substantially shorten motor life.

**NOTICE**

1. Lowering the minimum speed setpoint may adversely affect motor start-up characteristics.
2. Do not allow any sleeve bearing motor to operate below 500 RPM. Operation below 500 RPM will substantially shorten bearing life.

### SPEED CONTROLLER RPM RANGE

HP	RPM	MAX. RPM	MIN. RPM
1/30	1650/1500/1350 <sup>2,3</sup>	1650 <sup>4</sup> 1500 <sup>5</sup>	1300 <sup>4</sup> 950 <sup>5</sup>
1/8			
1/15	860	860	500
1/8			
1/6			
1/4			
1/2			
1/8	1140	1140	900
1/6			
1/4			
1/2			
1	1725	1725	1200
1/3			
1/2			
3/4			

**NOTES:**

1. Speed control available only with 115/60/1 open motors (thermally protected).
2. Three-speed motor (multiple tap winding).
3. Speed control should not be connected to low speed tap on motor because of starting characteristics.
4. Speed control connected to high speed tap on motor.
5. Speed control connected to medium speed tap on motor.

### SPEED CONTROLLER SIZE

MOTOR				SPEED CONTROLLER DESIGNATION / FLA		
HP	RPM	VOLTAGE	ENCLOSURE	66805601 5 AMP	66805701 10 AMP	66806001 15 AMP
1/8	1650/1500/1350	115V	Open	X		
1/15	860	115V	Open	X		
1/8	860	115V	Open	X		
1/6	860	115V	Open	X		
1/4	860	115V	Open	X		
1/2	860	115V	Open		X	
1/8	1160	115V	Open	X		
1/6	1160	115V	Open	X		
1/4	1160	115V	Open	X		
1/2	1160	115V	Open		X	
1	1160	115V	Open			X
1/3	1725	115V	Open		X	
1/2	1725	115V	Open		X	
3/4	1725	115V	Open			X

### Low End Setpoint Adjustment

**NOTE:** 5 amp model shown. On 10 and 15 amp models, adjustment is made through clearance hole in heat sink. The faceplate must be removed on the 5 amp model to access this screw.

## DRIVE MOUNTING

(REFER TO SAFETY SECTION)

Mount drives as follows:

1. Slip (do not pound) proper sheave onto corresponding shaft. Most drives utilize tapered bushings. Draw the bushing up evenly tightening in steps. To minimize bearing loading, mount sheaves as close to bearings as possible. It is preferable to use alignment tools that align the grooves of the sheave.
2. Laser alignment is common. The mechanic must be familiar with the alignment tool he is using. Otherwise, align sheaves with straightedge extended along sheaves, just making contact in two places on outside perimeters of both sheaves. This “four-point” alignment may also be checked with a string tied to the shaft behind one of the sheaves. The string is then pulled taut over the faces of the sheaves to check the alignment at the four points at the outside perimeters. Each sheave should be rotated about one-half revolution during this check to look for excessive runout or a bent shaft. Unless there is a bent shaft, runout can be corrected by adjustments to the bolt torque of the taper bushing.
3. Install and tighten the belts. Run the drive for a few minutes to seat the belts. When fitting the belts, slide the motor in to fit the belts on. Do not use a pry bar, as this may damage the belt cords. Tighten the belts to the proper tension. Ideal tension is just enough tension so that the belts do not slip under peak load or acceleration. Many drives are provided with tensioning data, which identifies the load to apply at the center of the span and the allowable deflection from this force. A belt tension gauge is recommended for precise tensioning.
4. After initial installation of belts, recheck belt tension again after a few days of operation to adjust belt tension. (New belts require a break-in period of operation.)



CLICK TO VIEW OUR  
SHEAVE INSTALLATION VIDEO

## THREE-PULLEY (IDLER SHEAVE) ASSEMBLY

Single bolt belt adjustment (see figure to right) can be made by loosening the idler sheave bolt (with  $\frac{3}{4}$ " wrenches) and moving it to the point where proper tension is achieved, per page 13, Figure 2. Alignment is necessary prior to belt adjustment. See Figure 3.

This configuration is standard on BCRD sizes 070-160 and BCRU (family) sizes 110-180. All other adjustments are made by moving the motor.



### WARNING

When working around belts and pulleys, keep hands away from pinch points.

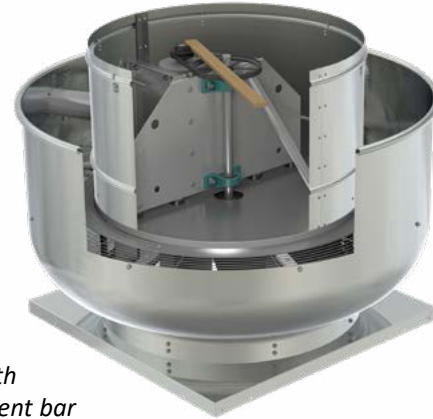

Fan with  
alignment bar

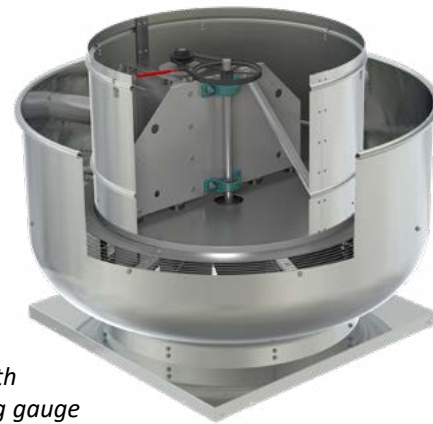

Fan with  
leveling gauge



### CAUTION

Placing fan sheave on motor can overspeed impeller and cause structural failure.

Three-Pulley (Idler Sheave) Assembly

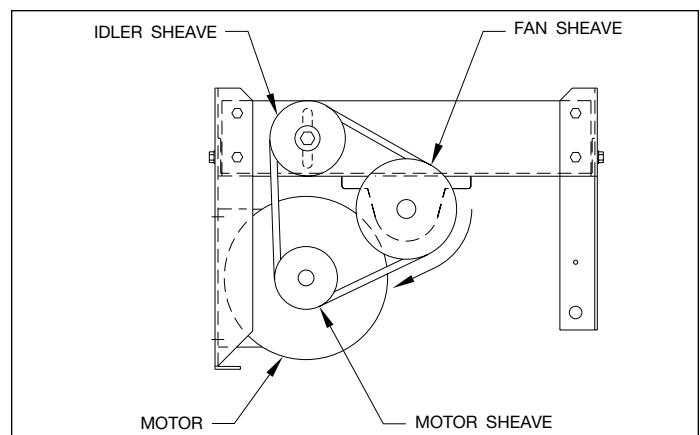

**V-BELTS** (REFER TO SAFETY SECTION)

V-belts on these belt driven fans are oil, heat and static resistant type and oversized for continuous-duty. With proper installation and maintenance, years of operating efficiency can be added to the lifespan of the V-belt drive.

The condition of V-belts and the amount of belt tension should be checked prior to start-up (see Figure 1). When it becomes necessary to adjust belt tension, do not over-tension as bearing damage will occur. Recommended belt tension should permit 1/64" deflection per inch of span of the belt at the center of the belt span. To find this point, measure halfway between the pulley centerlines as shown in Figure 2. Extreme care must be exercised when adjusting V-belts as not to misalign the pulleys. Any misalignment will cause a sharp reduction in belt life and will also produce squeaky, annoying noises (see Figure 3). On units equipped with 2 groove pulleys, adjustments must be made so that there is equal tension on all belts (see Figure 4).

1. Where tensioning rods are not provided, adjustment is more easily obtained by loosening and adjusting one side of the motor bracket at a time.
2. Always loosen tension adjustment enough to place belts on sheaves without running belts over the edge of either sheave. A new belt may be seriously damaged internally by careless handling (see Figure 5).

**WARNING**

**When removing or installing belts, never force belts over pulleys without loosening the motor first to relieve belt tension.**

3. Fan speed can be increased by closing the adjustable motor pulley or decreased by opening it. Always check the load on the motor when increasing the fan speed.

Figure 1. Eliminate Slack

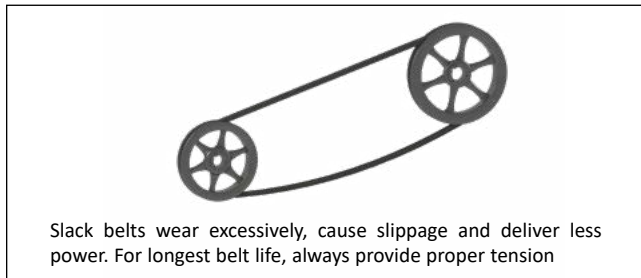

Figure 2. Belt Deflection

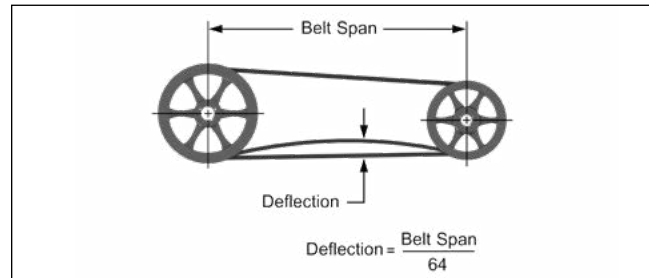

Figure 3. Alignment

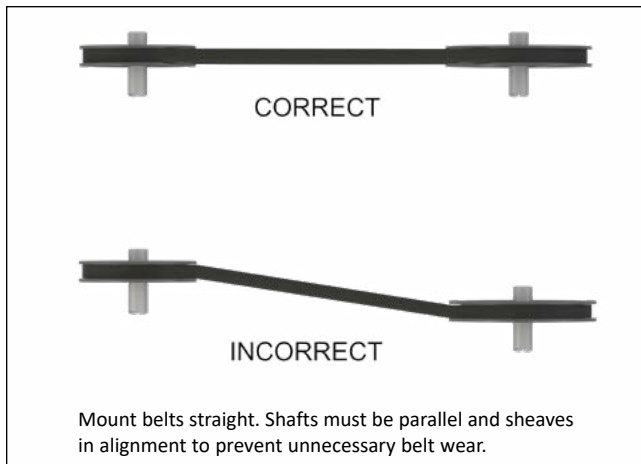

Figure 4. Two-Groove Sheaves (Pulleys)

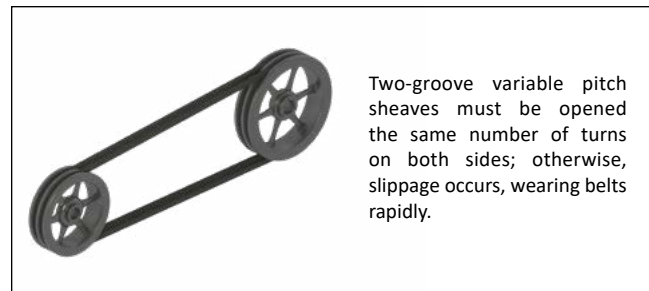
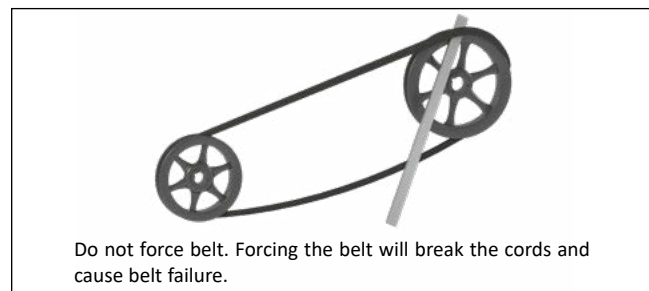

Figure 5. Belts



## CHECK, TEST & START PROCEDURE



### WARNING

1. Electric shock hazard. Could cause severe injury or death. Failure to bond the frame of this equipment to the building electrical ground by use of the grounding terminal provided or other acceptable means may result in electrical shock. Disconnect electric power before servicing equipment. Service to be performed only by qualified personnel. Make sure power is turned off and locked in the OFF position.
2. Rotation is critical. If allowed to operate in the wrong direction, the motor will overload and burn out.
3. Especially check three-phase units for rotation. For three-phase, rotation can be changed by interchanging any two of the three line leads. If the unit is checked on temporary wiring, it should be rechecked when permanently installed. Motor burn-out or tripped overload protection devices are usually the result of wrong rotation.

1. Check to verify that the impeller is free to rotate.
2. For optimum fan performance make sure that the impeller to inlet venturi gap or overlap is maintained. See *Impeller to Inlet Venturi* table.
3. Verify that supply voltage on the line side of disconnect agrees with voltage on fan data plate and is within the 10% utilization voltage.
4. Apply power to unit and check rotation of impeller with the directional arrow on the unit. See *Impeller Rotation* table.
5. Electrical Input Check: Perform check of fan ampere draw and verify that motor nameplate amps are not exceeded. Take into account the service factor range if motor is nameplated above a 1.0 service factor.
6. Fan RPM should be checked and verified with a tachometer.
7. Units with Speed Control (Direct Drive): Verify that speed controller gives desired operating range of RPM. If minimum speed value is not desired, it may be adjusted. See page 11.

#### IMPELLER ROTATION\*

MODEL	CCW	CW
BCRD	070, 075	all other
BCRU/UR/USH/W/WR	160, 180	all other
BCLH/BCLP	070, 075	all other
DCRD	all	---
DCRU/UR/W/WR	all	---
DCLH/DCLP	all	---

\* Impeller rotation is determined when viewed from top of fan (opposite air intake).

**Note:** On fans with three phase motors the impeller rotation can be changed by reversing any two power leads.

Fan Impeller Rotation - View from Exhaust End

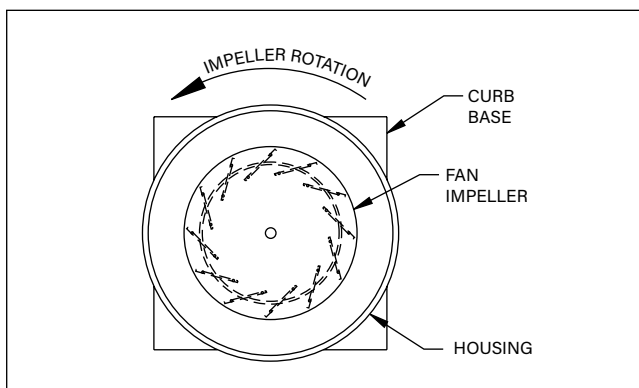

**Note:** CCW rotation shown, CW rotation is similar but opposite.

### NOTICE

The fan was balanced at the factory to be within stringent vibration levels before shipment. However, there are several things that may cause vibration, such as rough handling in shipment and installation, weak foundations and alignments.

#### IMPELLER TO INLET VENTURI

MODEL	GAP	OVERLAP
BCRD 070D, 075D	---	0.25
BCRD*	---	0.50
BCLH/BCLP	---	0.50
BCRU/UR/USH/W/WR 160B, 180B	0.06	---
BCRU/UR/USH/W/WR**	---	0.50
BCRU/UR/USH/W/WR 420B, 480B	---	0.75
DCRD	0.25	---
DCLH/DCLP	0.25	---
DCRU/UR/W/WR	0.06	---

\* all sizes except 070 and 075.

\*\* all other sizes, including 160/180 BMP/BHP.

**MAINTENANCE** (REFER TO SAFETY SECTION)

Installation and maintenance are to be performed only by qualified personnel who are familiar with local codes and regulations and experienced with this type of equipment. Preventive maintenance is the best way to avoid unnecessary expense and inconvenience. Start-up and routine maintenance should cover the following items:

- a. Tighten all set screws, bolts and wire connections.
- b. Check belt tension and sheaves for wear.
- c. Lubricate fan bearings (see tables below).
- d. Cleaning of unit, impeller and damper (if present).

All motors containing ball bearings are permanently lubricated from the factory. No additional maintenance is required.

**SUGGESTED FAN BEARING GREASING INTERVALS**

INTERVAL (MONTHS)	TYPE OF SERVICE
12 to 18	Infrequent operation or light duty in clean atmosphere.
6 to 12	8 to 16 hrs./day in clean, relatively dry atmosphere.
3 to 6	12 to 24 hrs./day, heavy duty, or if moisture is present.
1 to 3	Heavy duty in dirty, dusty locations; high ambient temperatures; moisture laden atmosphere; vibration.

 **CAUTION**

1. Sharp edges and screws are a potential injury hazard. Avoid them.
2. Greases of different soap bases (lithium, sodium, etc.) may not be compatible when mixed. Prevent such intermixing by completely purging the bearing of old greases.

 **WARNING**

Hazardous moving parts. Unit may contain protected fan motor that may start automatically and cause injury. Allow time for reset. Disconnect power before servicing.

**GREASE MANUFACTURERS**

MANUFACTURER	GREASE (NLGI #2)
Shell	Gadus S2 V100 2 or equivalent
Exxon/Mobil	Ronex MP

1. Before performing any maintenance on the fan, be sure power is turned off and locked in the OFF position at the service entrance.
2. Ventilators should be carefully checked at least once a year. For critical or rugged applications, a routine check every two or three months is suggested.
3. All motors supplied with Twin City Fan ventilators carry a one-year limited warranty from date of shipment. For repairs within the warranty period, the motor must be taken to the motor manufacturer’s authorized service dealer. Contact your representative for additional warranty details.
4. A periodic motor check should consist of spinning the motor shaft with the power off to be sure the motor turns freely and the bearings run smoothly. The belt on belt driven units should be removed from the motor sheave.
5. When removing or installing a belt, do not force the belt over the sheave. Loosen the motor mount so that the belt can be easily slipped over the sheave.
6. The belt on belt driven units should be removed and carefully checked for glazing, cracks, ply separation or irregular wear. A small irregularity in the contact surface of the belt will result in noisy operation. If any of these defects are apparent, the belt should be replaced. Check the sheaves also for chipping, dents or rough surfaces that could damage the belt.
7. The correct belt tension is important. Too tight of a belt will result in excess bearing pressure on the motor bearings and shaft pillow blocks and may also overload the motor. Too loose of a belt will result in slippage, which will quickly “burn” out belts. A belt should feel “live” when thumped, approximately ¼" belt deflection (3 to 5 lb.) when subject to finger pressure at midpoint between sheaves.
8. The belt alignment should also be checked to be sure the belt is running perpendicularly to the rotating shafts. Fan and motor shafts must be parallel. Improper alignment will result in excessive belt wear.
9. Check sheave set screws to ensure tightness. Proper keys must be in keyways.
10. Do not readjust fan RPM. If sheaves are replaced, use only sheaves of identical size and type.
11. If unit is to be left idle for an extended period, it is recommended that belts be removed and stored in a cool, dry place to avoid premature belt failure.

## MAINTENANCE (CONTINUED)

12. The standard pillow block bearings on belt driven ventilators are factory lubricated and are provided with external grease fittings. Lubrication annually is recommended or more frequently if needed (see Greasing Intervals table).

It is recommended to add fresh grease at start-up, but do not over-grease. Use only 1 or 2 shots of a recommended lubricant with a hand gun in most cases (see Grease Manufacturers table). Maximum hand gun rating 40 P.S.I. Rotate bearings during lubrication where good safety practice permits.

The most frequent causes of bearing failure are not greasing often enough, using an excessive quantity of grease or using incompatible greases. Excessive vibration, especially if the bearing is not rotating, will also cause bearings to fail. Bearings must also be protected from water and moisture to avoid internal corrosion.

13. During the first few months of operation it is recommended that the bearing set screws be checked periodically to ensure that they are tight.

14. The rotating impeller requires particular attention since materials in the air being handled can build up on the blades to cause destructive vibration or weaken the structure of the impeller by corroding and/or eroding the blade metal. Regular inspection and corrective action at intervals determined by the severity of each application are essential to good service life and safety.

## MOTOR LUBRICATION

Motors that contain ball bearings are permanently lubricated from the factory. No additional maintenance is required.

Motors that contain sleeve bearings require lubrication every six (6) months. Use SAE-20W lubricant and add five (5) drops to each location shown in figure on the right. **DO NOT OVER LUBRICATE.**

SLEEVE BEARING MOTOR OIL TUBE LOCATION

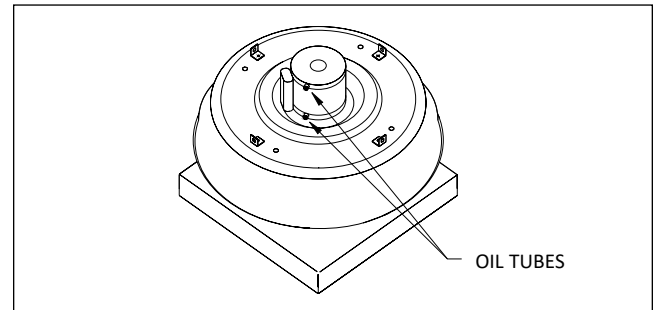

## DUCT CONNECTIONS

(REFER TO SAFETY SECTION)

The ductwork is run into the inside of the roof curb and connected to the curb. This must be done before the fan is mounted to the roof curb. The duct must be equal to or larger than the inlet of the fan.

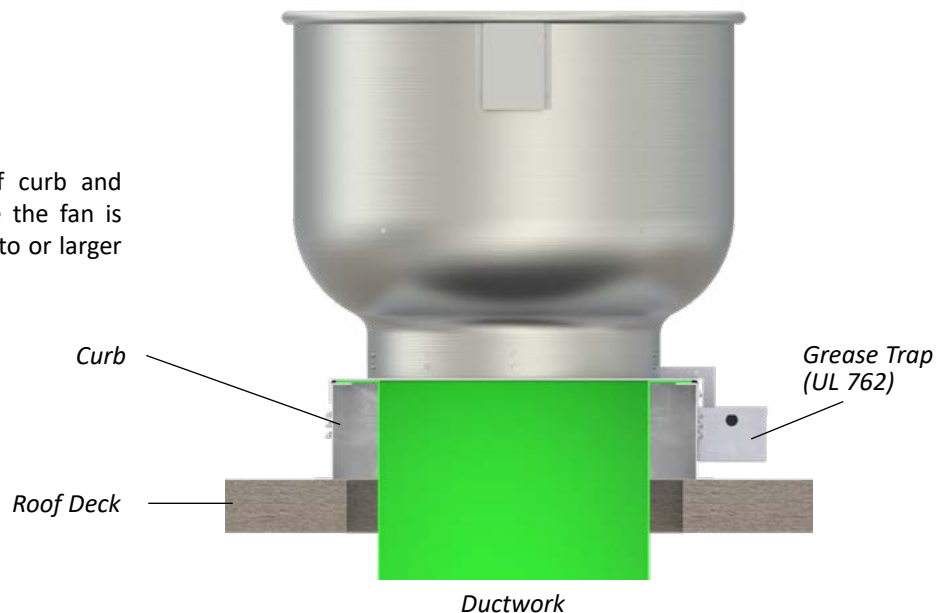

## OPTIONAL ACCESSORIES

1. **Backdraft Damper** — Backdraft dampers, with automatic or motorized operation, feature a felt seal on the edge of the damper blades for quiet operation. Damper frames are constructed of 19-gauge galvanized steel and blades are constructed of 26-gauge aluminum. Motorized dampers are recommended for low CFM applications to assure unrestricted airflow. Motorized dampers are available with 115, 208, 230, 460, 575 or 24 volt service. End switches are available. When a motorized damper option is selected a 12" (or greater) high roof curb is required.

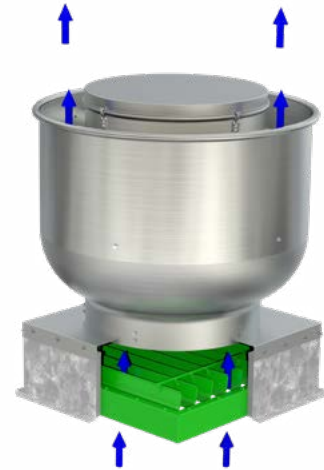

2. **Roof Curbs** — Prefabricated roof curbs are available in heavy-duty galvanized steel or aluminum construction, in heights of 8", 12" or 18". The canted curb is provided with a factory installed wood nailer. Curbs are provided with 1.5" of insulation as standard and feature continuously-welded seams for added rigidity and moisture protection. Prefabricated curbs are also available in raised cant, pitched and peak models. Refer to Catalog 4910 for complete details on roof curb options. Minimum 12" high curbs are recommended for use with motorized dampers.



*Self-Flashing Roof Curb*

3. **Automatic Belt Tensioner** — Spring loaded pulley used for automatic belt tensioning. Eliminates the need for regular belt tensioning and extends belt life.

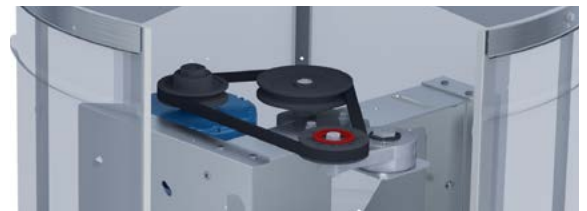

4. **Curb Hinge** — The curb hinge arrangement provides easy access to the exhaust fan, backdraft damper and duct for servicing and cleaning. The curb hinge is of the piano type, running the entire length of the fan's curb cap. The curb hinge option ships loose and is designed for use with a standard canted curb only (1.5" less than fan base). This option cannot be used with self-flashing curbs. See page 19 for installation instructions.



5. **Disconnect Switches** — NEMA 4 disconnect switches provide positive electrical shutoff when fan cleaning or maintenance of fan and is water and dust tight. Switch is available shipped loose for field mounting and wiring or factory mounted and wired. NEMA 3R enclosure is also available.

**OPTIONAL ACCESSORIES (CONT.)**

6. **Variable Speed Control** — Variable Speed Control is an optional accessory on all direct drive models within this manual with 115 volt, open type motors, to allow the adjustment of airflow for system balancing. Variable speed controllers are solid-state (Tri-ac) design and are designed to start the motor on high speed for better startup characteristics. Variable speed controls can be shipped separately, factory installed or field installed on the unit at a later date. Motor must be ODP 115V, PSC or shaded pole type.



7. **Miami-Dade Construction** — All sizes on model DCRD and sizes 070-360 on model BCRD are available with optional Miami-Dade Hurricane Construction. With this option, units are rated for wind loads up to 150 miles per hour. In conjunction with independent, licensed Florida Professional Engineers, these fans have undergone rigorous design, analysis and testing to ensure they meet the stringent product requirements of Miami-Dade County. Twin City Fan’s NOA (Notice of Acceptance) number is 26-0312.02 and can be found on the Miami-Dade County website.

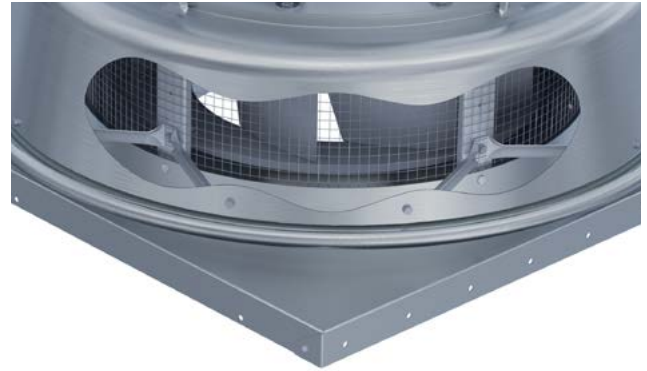

**SERIAL NUMBER & FAN TYPE**

The serial number and fan type can be found on our permanent nameplate of the fan.

 <b>TWIN CITY FAN</b>		<b>TWIN CITY FAN &amp; BLOWER</b> MINNEAPOLIS, MN   WWW.TCF.COM	
MODEL	BCRD	DATE	
SER. #	09-265399-1-1	DATE	
VOLTS		HZ	SIZE
HP		PHASE	CLASS
MAX. RPM		ENCL.	ARR.
TAG			
<b>PARTS &amp; SERVICE</b>			500024209
888-444-4823   FIELDSERVICE@TCF.COM   PARTS@TCF.COM			



## CURB HINGE INSTALLATION

The curb hinge is only available on standard, canted roof curbs with dimensions 1.5" smaller (L x W) than the fan base. The curb hinge is not available on self-flashing curbs. The curb hinge mounts directly to the outside of the roof curb and the inside of the fan's curb cap with the hardware provided.

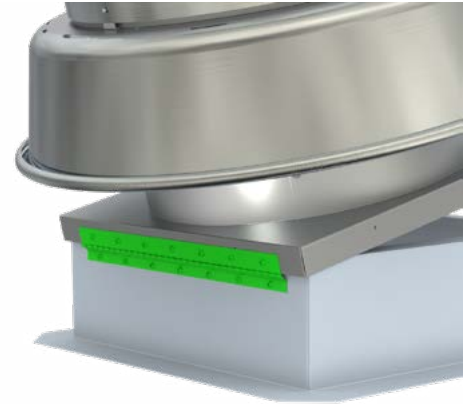

Item	Part Number
Curb Hinge Assy (Size 070 - 080)	1009594
Curb Hinge, 15.0"	56482701
1/4-20 x 0.50" Lg Self-Tap Screw (Qty 8)	HDW-SCREW025-20X050TAPZ
Parts Bag	92672410

**STEP 1:** Align the holes on the curb hinge to the holes on the curb cap. This should be on the opposite side of the drain, if applicable.

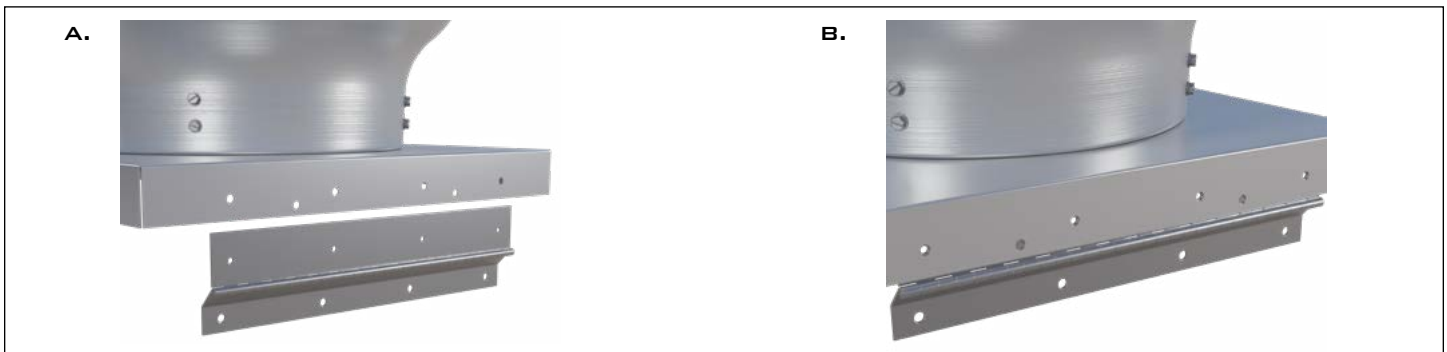

**STEP 2:** Insert provided screws to affix the hinge to the curb cap.

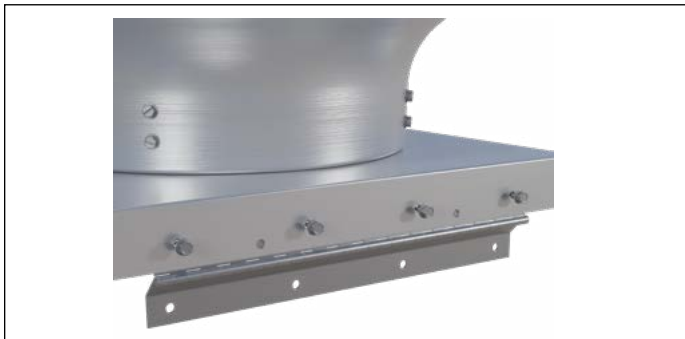

**STEP 3:** Place and install fan onto the roof curb.

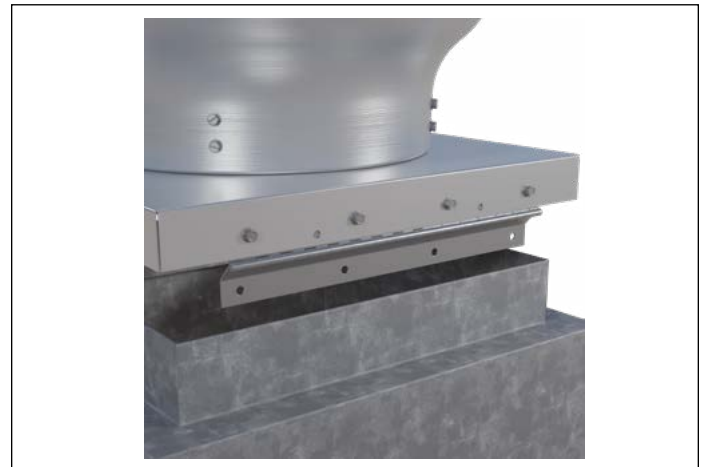

**STEP 4:** Properly align the fan with the roof curb. Pre-drill holes for securing hardware.

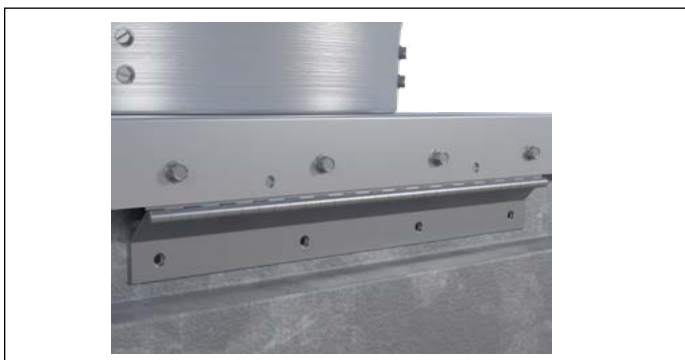

**STEP 5:** Fasten hinge to roof curb with customer provided hardware.

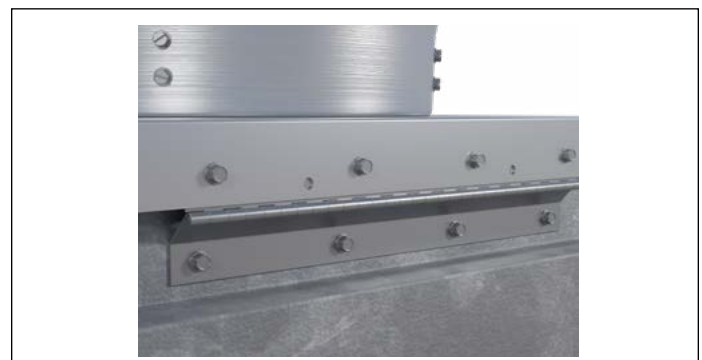



## SECURITY HASP INSTALLATION

A security hasp is available in conjunction with the curb hinge to prevent removal of the unit from the unit curb cap and prevent entrance into the building through the roof's ductwork.

Item	Part Number
10-32 x 3/4", Bolt, Hex (4)	HDW-BOLT019X075Z
#10, Fastener (4)	
#10, Star Washer (4)	HDW-WASHER019STARIXTZ
#10, Nut Hex (4)	HDW-NUT019-32SS
Security Hasp, Hinged	92487110
Parts Bag	92672410



*Properly mated security hasp*

**STEP 1:** Drill (4) 0.19 holes on center curb cap from either corner.



**STEP 2:** Attach the hasp to the curb cap by using the included #10 hardware.



**STEP 3:** Drill (4) 0.19 holes on center of roof curb, 2" from curb cap edge to top edge of staple.



**STEP 4:** Fasten staple with screws on roof curb.



## RETAINING CHAIN INSTALLATION

Follow these step by step instructions for installing the retaining chain.

**STEP 1:** Drill two 1/4" diameter holes, one each corner of curb base.



**STEP 2:** Attach chain to outside of curb base with bolt head on inside of curb base.



**STEP 3:** Use one flat washer under bolt head and one on top of chain.



**STEP 4:** Use remaining fasteners to attach other end of chain to anchor point.





## GREASE BOX INSTALLATION

Follow these instructions for installing the grease box.

**STEP 1:** Fasten the grease box to the curb cap under the drain, using supplied hardware.



**NOTE:** Part number to reorder grease pad is 68110208.

## FIRESTAT INSTALLATION

Follow these step by step instructions for installing the firestat accessory.

**STEP 1:** Attach the bracket provided to the motor housing support using the self-tapping screws that are fastened to the support post.

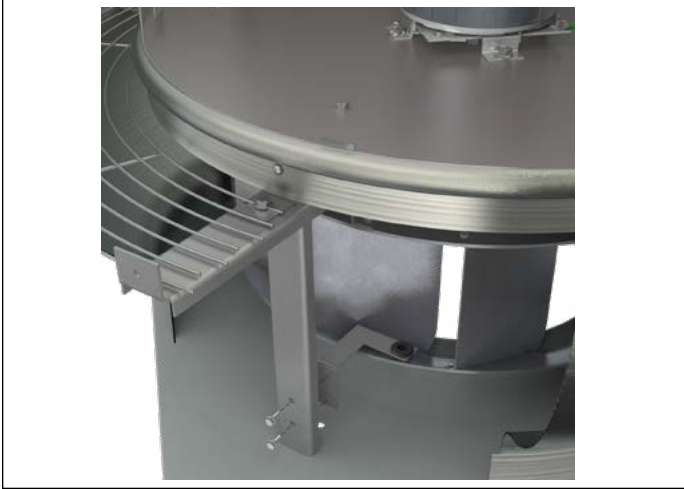

**STEP 2:** Drill holes and install firestat. Holes must be near a support post. Note: The hole drilled in the motor housing must be close to in line with the hole in the bracket provided.

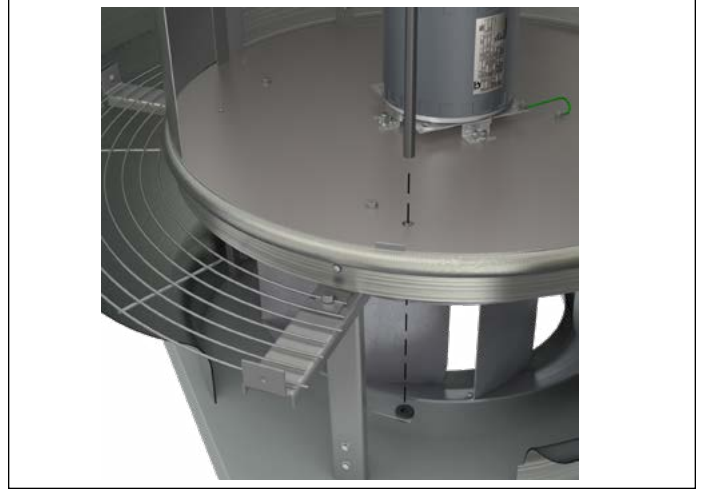

**STEP 3:** Cable tie sensing bulb to the nearest vertical support post.



**STEP 4:** Wire the firestat to the disconnect switch and motor.

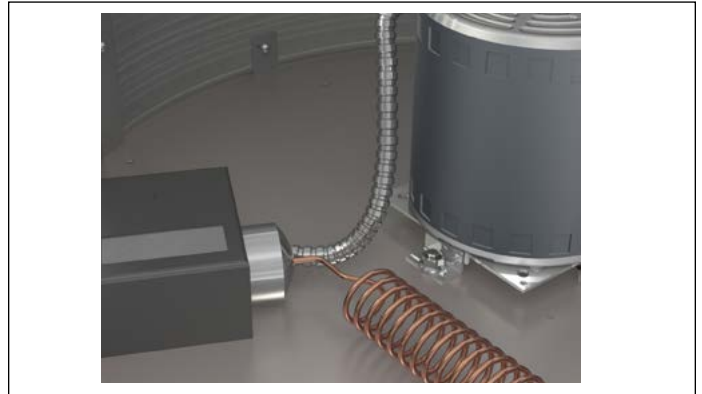

### INSECT SCREEN INSTALLATION

Follow these step by step instructions for installing the insect screen.

**STEP 1:** Place the insect screen between the fan inlet and the roof or roof curb. Fasten with screws or nails, if desired.



### PERFORMANCE BAFFLE INSTALLATION

Follow these step by step instructions for installing the performance baffle.

**STEP 1:** Place the performance baffle between the fan inlet and the roof or roof curb. Fasten with screws or nails, if desired.

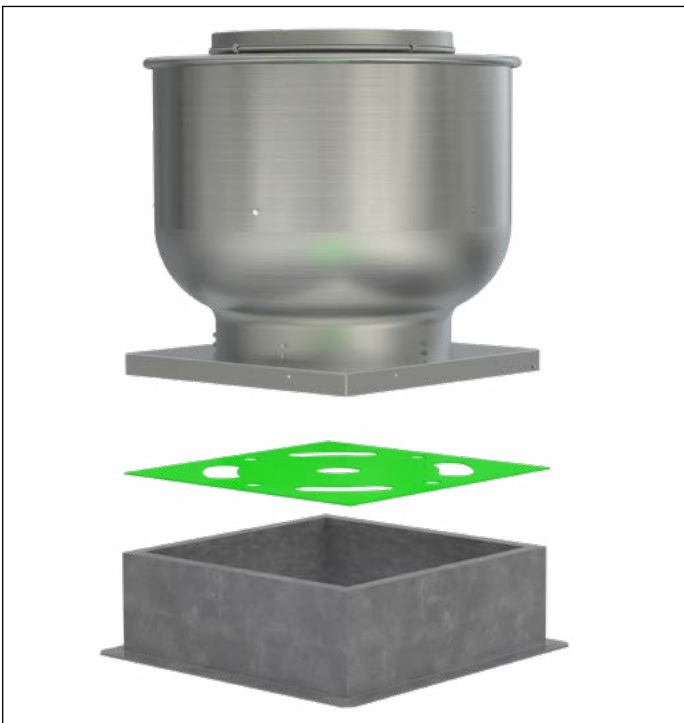

## TROUBLESHOOTING GUIDELINES

Use current safety practices when investigating fan or system performance problems. General safe practices and performance troubleshooting guidelines can be found in AMCA Publications 410 and 202, respectively. Fan application and field measurement procedures can be found in AMCA Publications 201 and 203.

Below is a list of possible areas to check when air or sound values do not match expectations. Most fan problems can be pinpointed to one of these common causes.

### Air Capacity Problems

1. Resistance of the system is not at design rating. If resistance is lower than expected, both airflow and horsepower may be up. If resistance is higher than anticipated, air volume will be down.
2. Fan speed is not at design speed.
3. Air density is not at the design value. Also check air performance measurement techniques/procedures.
4. Devices for air modulation are closed or plugged. Also check filters.
5. Impeller mounted improperly or is rotating in reverse.
6. Parts of the system or fan have been damaged or need cleaning.

### Noise Problems

1. Air performance is incorrect and the fan is not at design point of operation. Fan is being forced to operate in an unstable flow region near peak or to the left of the peak of the curve.
2. Bearing failure. Check bearings (lubrication).
3. Supply voltage high or inconsistent supply frequency. Adjustable frequency controllers can generate motor noise.
4. Objects that are installed in a high velocity airstream can generate noise. This includes flow sensors, turning vanes, etc.
5. Poor fan inlet conditions.
6. Acoustics or sound measurement procedure incorrect.

### Vibration Problems

1. Misalignment of drive components. Check belt or coupling.
2. Poor foundation or mounting structure (resonances).
3. Foreign material attached to rotating components.
4. Damaged rotating components (bearings, shaft, fan, impeller, sheaves).
5. Broken, loose or missing set screws.
6. Loose hardware.
7. Vibration transmitted by another source.
8. Fan is operating in stall or unstable flow region.

### Motor Problems

1. Incorrect wiring.
2. Speed of fan too high.
3. Parts improperly installed; binding.
4. Bearings improperly lubricated.
5.  $WR^2$  capability of motor too low for application.
6. Protection devices may be improperly sized.
7. VFD compatible electrically? Effective shaft grounding?
8. Is cabling and grounding correct?

### Drive Problems

1. Belts improperly tensioned.
2. Drive alignment is poor. Check belt or coupling.



### NOTICE

All fans manufactured by Twin City Fan are factory balanced prior to shipment. Installation variables, handling and movement of the fan during shipment may cause the rotating assembly to shift. Balance should be checked once the fan is installed. If a final trim balance is required, it is the end user's responsibility to bring the fan back to factory specifications. Final trim balancing is not the responsibility of Twin City Fan. Refer to the Vibration Guidelines table below.

### VIBRATION GUIDELINES

Condition	Fan Application Category	Rigidly Mounted mm/s (in./s)	Flexibly Mounted mm/s (in./s)
Start-up	BV-3	6.4 (0.25)	8.8 (0.35)
	BV-4	4.1 (0.16)	6.4 (0.25)
Alarm	BV-3	10.2 (0.40)	16.5 (0.65)
	BV-4	6.4 (0.25)	10.2 (0.40)
Shutdown	BV-3	12.7 (0.50)	17.8 (0.70)
	BV-4	10.2 (0.40)	15.2 (0.60)

Values shown are peak velocity, mm/s (inches/s), Filter out. Table taken from ANSI/AMCA Standard 204-05, Table 6.3. AMCA defines BV-3 for applications up to 400 HP; BV-4 for applications over 400 HP.





# INSTALLATION/START-UP CHECKLIST

Become familiar with the equipment by looking at the fan assembly drawing for special instructions and accessories.

## INITIAL FAN CHECK

- Inspect fan for damage
- Check foundation, prepare for shims
- Level the fan
- Check bolt tightness
- Check to see if the fan is distorted by the foundation and/or ductwork  
*Note: Applies to direct or isolation mount.*
- Check fan interior for debris and standing water

### Fan Impeller

- Impeller clearance checked
- Impeller overlap checked
- Fasteners tight
- Impeller rotates freely

### Bearings

- Bearings aligned
- Bearings greased  
*Note: Rotate while greasing*
- Set screws tight (if equipped)

### Lube Lines

- Lube lines have been charged with grease prior to connecting to bearings

### V-Belts (if equipped)

- V-belt drives aligned
- Sheaves retightened
- Belt tension correct
- Motor bolts retightened

### Accessories

- Installed per drawing



**WARNING**

Verify that proper safety precautions have been followed. Electrical power must be locked off.

## ELECTRICAL COMPONENTS

- Motor wired for proper voltage
- Motor grounded
- Leads are properly insulated
- Accessories wired per instructions supplied.

## ENERGIZE

- Energize motor long enough to start assembly rotating, shut down
- Verify direction of impeller rotation, rewire if necessary *Note: Refer to Impeller Rotation section*
- Run the fan up to speed
- Check for excess vibration and listen for unusual noise. Refer to the *Vibration Guidelines* table in the *Troubleshooting Guidelines* section for vibration limits.
- Bearing temperatures should stabilize after a few hours. Less than 200°F  
*Note: Use sense of smell to identify possible electrical, belt issues.*

## AFTER ONE WEEK

- Verify bolt tightness
- Verify belt tension and adjust as necessary

**NOTICE**

Always observe site specific and regulatory safety precautions.

SERIAL NUMBER: \_\_\_\_\_

COMPLETED BY: \_\_\_\_\_

DATE COMPLETED: \_\_\_\_\_







TWIN CITY FAN & BLOWER | [WWW.TCF.COM](http://WWW.TCF.COM)

5959 TRENTON LANE N | MINNEAPOLIS, MN 55442 | PHONE: 763-551-7600 | FAX: 763-551-7601

© 1998-2026 TWIN CITY FAN COMPANIES, LTD.