

## Fan Damper Selection

### Introduction

Dampers offer a low cost, low maintenance alternative for controlling airflow in a fan system when compared to inverter drives or “in-flight” adjustable blade fans. In some types of fans, such as roof ventilators, dampers are standard, but in most instances they are sold as an optional accessory tailored to meet the requirements of individual applications.

A variety of damper types are offered that can be installed on either the fan inlet, outlet or at some remote location in the fan system. There are automatic dampers, manually operated dampers, motor operated dampers and modulated control dampers. There are varied degrees of construction from light to heavy, different blade shapes, end or center pivoted blades and parallel or opposed blade arrangements, all uniquely configured for specific applications.

The first part of this article will cover dampers and concepts associated with lower pressure systems incorporating panel fans, tubeaxial fans, vaneaxial fans and centrifugal vent set fans. Starting with “Volume Control Dampers” the discussion will favor the medium to high pressure systems commonly associated with centrifugal

fans. This is not to imply that the various dampers cannot be used interchangeably. The concepts still hold true for all fans and systems, and use would only be limited by choice or ruggedness of construction.

### Automatic Dampers

Automatic or backdraft dampers are commonly associated with wall exhaust or roof ventilator applications. Designed to open automatically when the fan is energized and to close by gravity when power is turned off, these parallel blade, end pivoted dampers provide a mechanism which prevents the air from back flowing through the system while also serving to exclude outside elements such as rain and snow. Typical wall and roof installations are shown in Figure 1.

Another type of automatic backdraft damper is referred to as a stack cap or a discharge cap. Stack caps are simply two opposed blade dampers mounted atop a roof fan, complete with a protective wind band that allows air to be exhausted while excluding the elements when not operating (see Figure 2).

Figure 1. Automatic Dampers

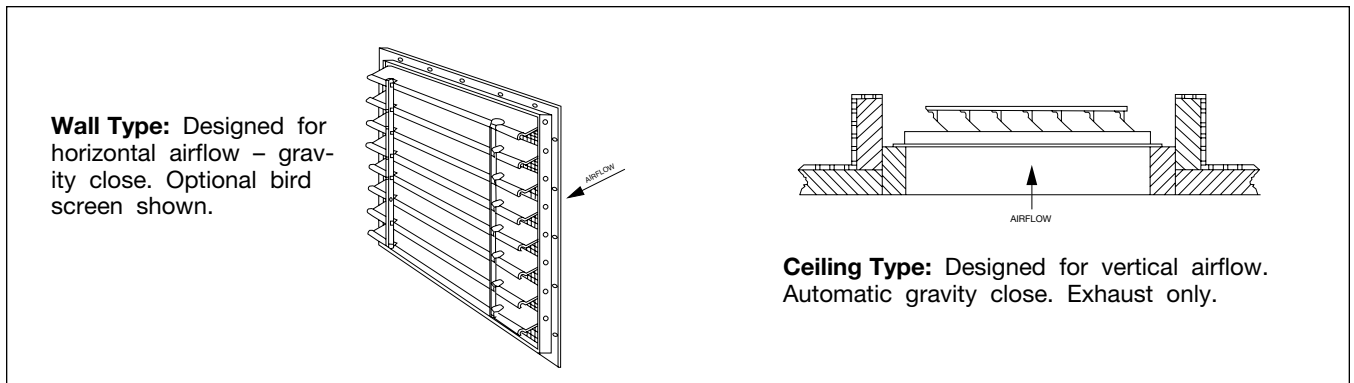
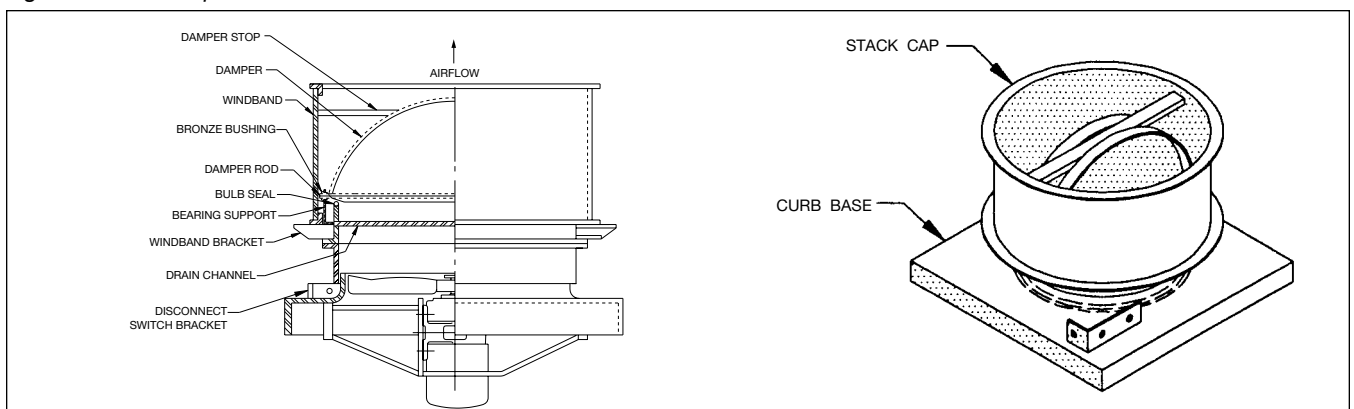

Figure 2. Stack Caps



In addition to exhaust applications, square, rectangular and circular automatic backdraft dampers are also used in certain duct systems to function as check valves to prevent reverse airflow through a fan during shut down. This is of particular importance in parallel fan systems, where the fans are cycled independently, to prevent “windmilling” of the fan that is not in operation.

These dampers are not intended for capacity control and therefore the system characteristics are altered only by the resistance required to fully open the blades.

## Motor Operated End Pivoted Dampers

The function of these dampers is similar to that previously described for automatic dampers. The difference is that they are usually furnished with a two-position electric actuator (Figure 3) that powers the blades open rather than relying on the velocity pressure of the airflow. This is of particular importance in low flow conditions that might otherwise only partially open the automatic damper blades creating blade flutter and potentially more noise.

Figure 3. Motor Operated, End Pivoted Damper

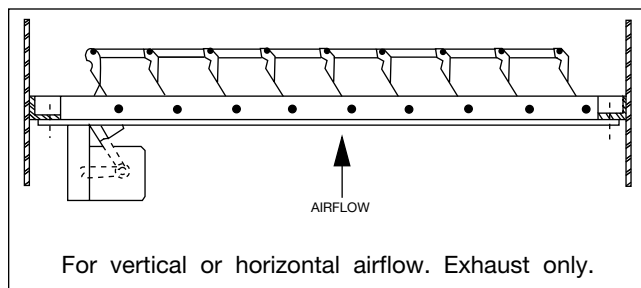

Another advantage of the motor operated damper is that when power is off the spring return insures positive closing of the blades and is not influenced by stray eddies or air currents.

Like the automatic damper, the two-position motor operated damper is not intended for capacity control and therefore the system characteristics are altered only by the resistance to airflow of the fully opened blades.

## Motor Operated Center Pivoted Dampers

The motor operated center pivoted damper (see Figure 4) can be used in either supply or exhaust applications. These dampers are used primarily in reversing airflow fans and in air handling systems that require the dampers to be open before the fan is energized.

Figure 4. Motor Operated, Center Pivoted Damper

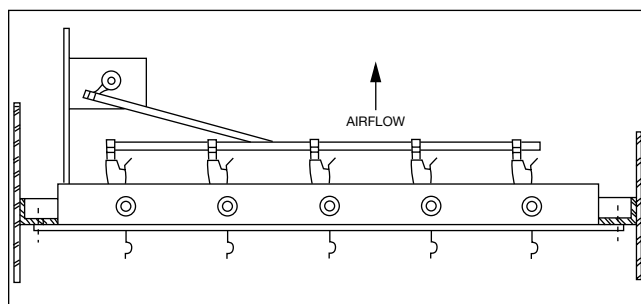

Designed for supply and exhaust.

The electric actuators for these dampers are provided with end switches that allow the damper to open before the fan motor is energized. And like the two-position actuator supplied on end pivoted dampers, when power is off the spring return insures positive closing of the damper blades.

System characteristics are altered only by the resistance to airflow with fully opened blades.

## Volume Control Dampers

Fan or system capacity can be altered over a finite range through gradual damper blade adjustments. These dampers can be located on the fan discharge (outlet dampers), the fan intake (inlet dampers) or any place in the system. These dampers may be manually controlled or controlled with sophisticated automatic systems.

## Outlet Control Dampers

Outlet control dampers are normally center pivoted with either “parallel” or “opposed” blade configuration (see Figure 5).

Figure 5. Outlet Control Dampers

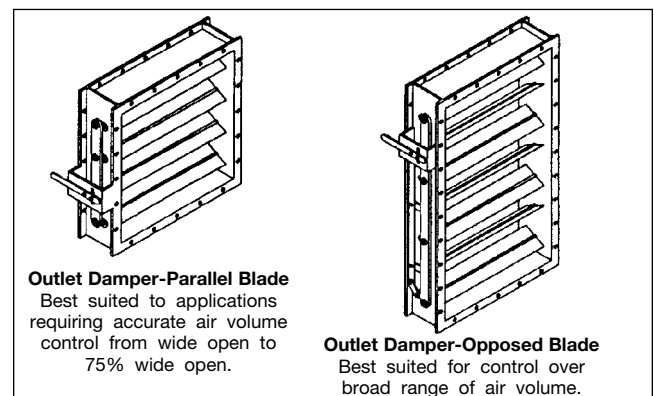

They can be mounted horizontally as shown, with the blades parallel to the fan shaft, or they can be mounted with the blades perpendicular to the fan shaft. Perpendicular blade orientation may require special bearing considerations.

As the blades are closed on the “parallel” blade damper the air tends to pile up on one side creating uneven airflow in the duct. This can lead to airflow distribution problems in branch ducts located too close to the damper. It can also lead to a system effect on fan performance when the damper is too close to the inlet of the fan.

Figure 6. Damper Airflow Characteristics

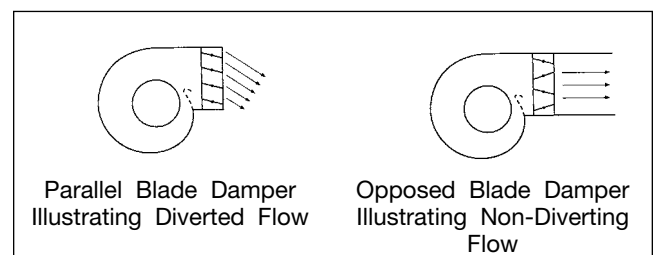

“Opposed” blade dampers are the preferred selection when it is necessary to maintain an even distribution of airflow immediately downstream of the dampers. The airflow characteristics of both the “parallel” blade and the “opposed” blade dampers are illustrated in Figure 6.

Also note in Figure 6, that as the damper lever arm is closed on the “parallel” blade damper, there is only a small reduction of area between the blades. Now compare this to the “opposed” blade damper, where for the same amount of lever arm travel there is a proportional reduction of area between blades. For example, a 30 degree closing of the lever arm on a “parallel” blade damper results in a capacity reduction of approximately 10 percent while the same degree of closing on an “opposed” blade damper will result in a capacity reduction of approximately 30 percent.

The small reduction in capacity for a relatively large lever arm travel makes the “parallel” blade damper the preferred choice where sensitive control of airflow between wide open and 75 percent of wide open is required. The “opposed” blade damper is selected when proportional control is desired.

The operating characteristics of a backward inclined

centrifugal fan and outlet damper combination can be seen in Figure 7.

The outlet damper controls the airflow after it passes through the fan by changing the resistance the airflow is working against.

Point 1 on the curve represents the fan system with a full open blade setting. As the damper blades are closed off the damper resistance increases, driving the operating point to the left along the fan’s static pressure curve. Points 2, 3, 4 and 5 represent the fan system for several different settings of damper blade closure. Note that as the damper resistance is increased, it moves the brake horsepower to the left along its curve, as noted by points 1a, 2a, 3a, 4a and 5a. On backward inclined centrifugal fans, as the damper is closed, the brake horsepower can be more or less than the “wide open” damper horsepower, but on forward curve and radial blade centrifugal fans, the brake horsepower will always be less than with the wide open setting.

Figure 7. Operating Characteristics of a Backward Inclined Centrifugal Fan With Outlet Dampers

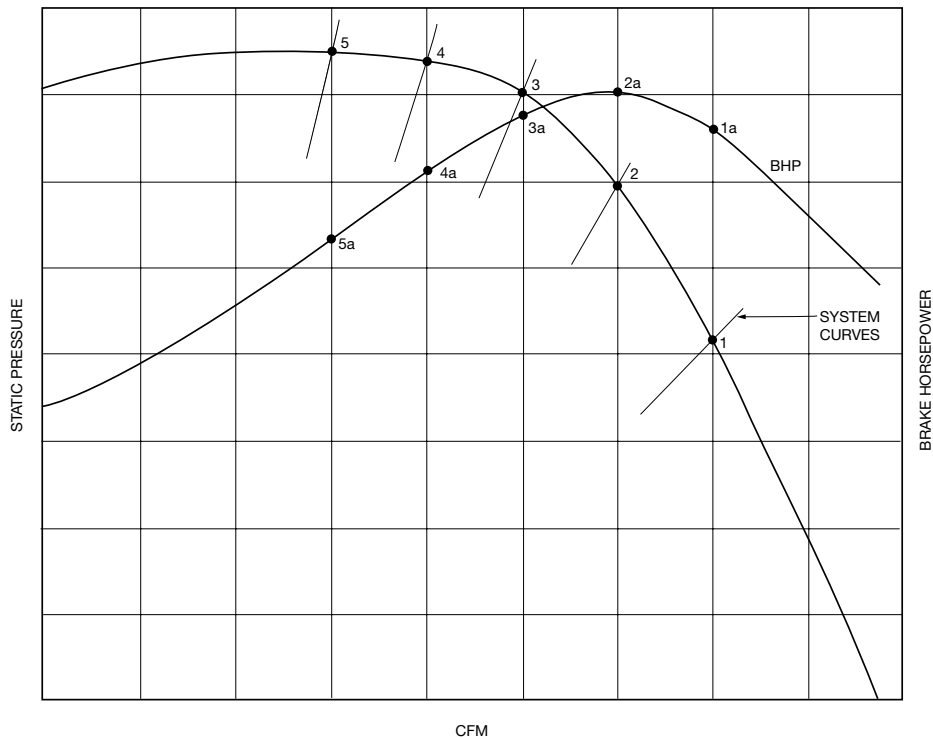

## Inlet Box Dampers

Inlet box dampers are used when volume control is required with a fan inlet box in lieu of a variable inlet vane. The performance of the inlet box damper is similar to the variable inlet vane, but allows for an easier means of control when an inlet box is used.

Inlet box dampers are typically constructed with rugged, two piece parallel blades that run along the narrow axis of the damper to preswirl the air as it enters the fan inlet. See the illustration below. The standard material of construction for the inlet box damper is mild steel, but special materials can be used based on airstream requirements. The dampers are constructed with relubricable bearings. When airstream temperatures are over 300°F, or system pressure dictates, the bearings are mounted on stuffing boxes that protect the bearings from the harsh airstream.

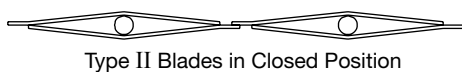

Type II Blades in Closed Position

Figure 8. Inlet Box Damper



## Inlet Control Dampers

Inlet box dampers, external inlet vane dampers and internal vane dampers are the most common forms of inlet control dampers. The inlet box damper (positioned properly) and both types of inlet vane dampers pre-spin the air in the direction of fan rotation. By creating spin in the direction of fan rotation, the airflow, pressure and horsepower of the fan are reduced, resulting in a new fan performance curve.

The inlet box damper is similar to the parallel blade outlet damper shown in Figure 5. Both types of inlet vane dampers are shown in Figure 9.

The external inlet vane damper is normally attached directly to the fan inlet flange. The vanes are center pivoted and operate parallel to each other. This damper is configured with a center hub, which allows the vanes to be supported on each end through pivot bearings. This type of construction makes the external vane damper capable of handling higher velocities and pressures than is possible with the internal inlet vane dampers. It also makes them more expensive. Another advantage of the external vane damper is that the control linkage is outside the air stream and easier to service.

The internal (nested) vane damper is constructed with the vanes assembled in the throat of the fan inlet cone. Because of this they are subject to much higher velocities than the equivalent external vane damper, resulting in higher pressure losses. For this reason the center hub is omitted in this design. This requires the center pivoted parallel vanes to be cantilevered off the inlet cone throat resulting in a construction that is better suited to lower pressures and velocities than the external vane damper. The internal vane damper is lower cost, more compact and easier to install than the external type.

Figure 10 shows potential performance curves of a fan with variable inlet vanes. The inlet damper produces

Figure 9. Inlet Control Dampers

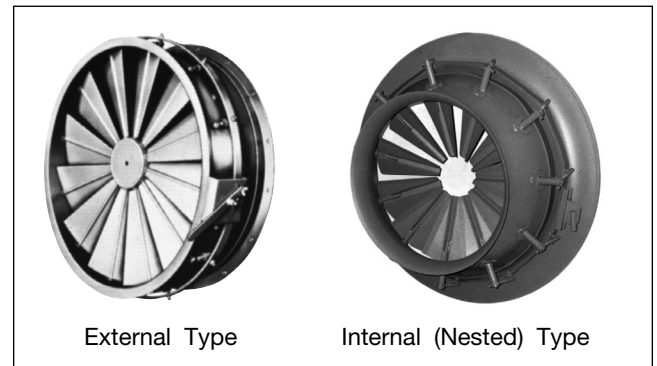

both a resistance and flow modifying effect by pre-spinning the air before it enters the fan wheel, generating a new performance curve for each vane position. The performance curve reacts very similar to a fan equipped with speed control.

Point 1 on the curve represents a fan system with a fully opened (90 degree) vane setting. Points 2, 3 and 4, and 2a, 3a and 4a show the reduction in airflow and horsepower for different angles of vane closing. Predicting the exact airflow and horsepower reductions varies with damper and fan type.

## Conclusion

While certain systems involving temperature, corrosives, airborne particulate, control sensitivity, etc., can limit the use of dampers, they still can offer impressive savings for most systems. They provide the system designer with a low cost and effective method to control system airflow. Although the power savings with outlet dampers may be substantial, even greater savings can be realized using inlet dampers.

Figure 10. Performance Curves of a Fan With Variable Inlet Vanes

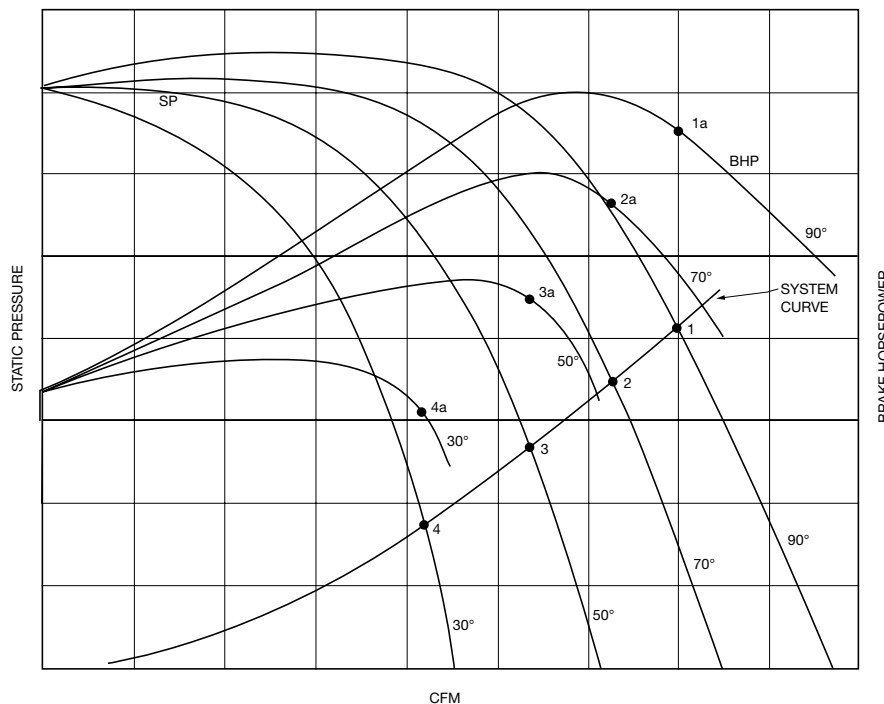

**TWIN CITY FAN & BLOWER | WWW.TCF.COM**

**5959 Trenton Lane N | Minneapolis, MN 55442 | Phone: 763-551-7600 | Fax: 763-551-7601**